

# COMMERCIAL STEEL DOORS & FRAMES



## DKS STEEL DOOR & FRAME SYSTEMS, INC.



### DKS STEEL DOOR & FRAME SYSTEMS, INC.

2142 S. Tubeway Avenue  
Commerce, CA 90040  
Tel: (323) 888-7763  
Fax: (323) 888-0063  
Email: [sales@dksdoors.com](mailto:sales@dksdoors.com)  
Website: [www.dksdoors.com](http://www.dksdoors.com)

### DKS ARIZONA WAREHOUSE

1725 W. Williams Drive, Suite 14  
Phoenix, AZ 85027  
Tel: (602) 698-7779  
Fax: (480) 383-6353  
Email: [sales@SWOpeningSolutions.com](mailto:sales@SWOpeningSolutions.com)

### DKS TEXAS WAREHOUSE

SSG Arlington Texas  
2020 Exchange Drive  
Arlington, TX 76011  
Tel: (817) 275-3070  
Fax: (817) 275-3068  
Email: [gregshuck@ssg-texas.com](mailto:gregshuck@ssg-texas.com)  
Website: [www.ssg-texas.com](http://www.ssg-texas.com)

SSG Houston Texas  
423 Blueberry  
Houston, TX 77018  
Tel: (817) 275-3070  
Fax: (817) 275-3068  
Website: [www.ssg-texas.com](http://www.ssg-texas.com)

### DKS PENNSYLVANIA WAREHOUSE

Tab Industries, LLC  
2525 North 12th Street  
Reading, PA 19605  
Tel: (610) 921-0012  
Fax: (610) 921-0014  
Website: [www.tabindustries.com](http://www.tabindustries.com)



**THIS PAGE INTENTIONALLY LEFT BLANK**



**Standard Features**

- ◆ 16 and 18 Gauge Doors
- ◆ Cold Rolled or Galvanized Steel
- ◆ Tight Corner Seam
- ◆ Full Body Polystyrene Core or Honeycomb Core
- ◆ Non-Handed Design
- ◆ 12-Gauge Closer Reinforcement
- ◆ 7-Gauge Hinge Reinforcement- Reversible
- ◆ 16-Gauge Flush Top Cap - Galvanized Standard / Heavy Duty
- ◆ 16-Gauge Inverted Bottom Cap - Galvanized
- ◆ Prime Painted Grey Two Part Epoxy Factory Applied, Baked On
- ◆ Standard Lock Preparations Include 161, Fed 86 Edge, Panic Bar Reinforced
- ◆ WHI / ITS up to 3 hour, Positive Pressure and  Smoke included
- ◆ Meets or Exceeds Standards for ANSI 250.4 and ANSI 250.8

**Typical Hardware Preparations**

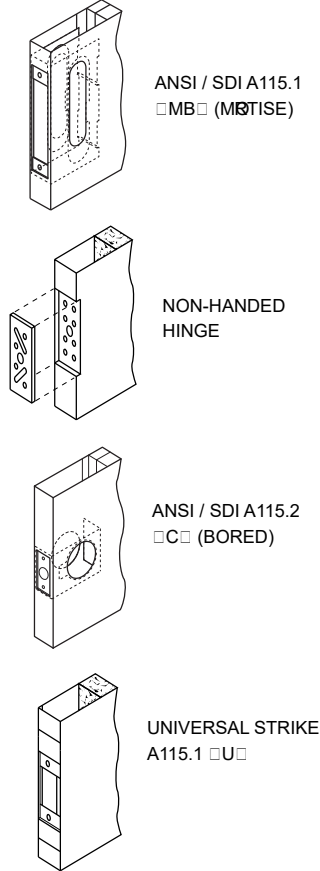

**Sections**

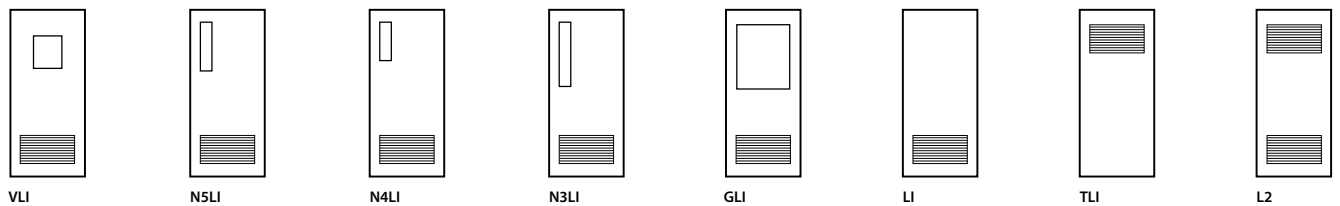
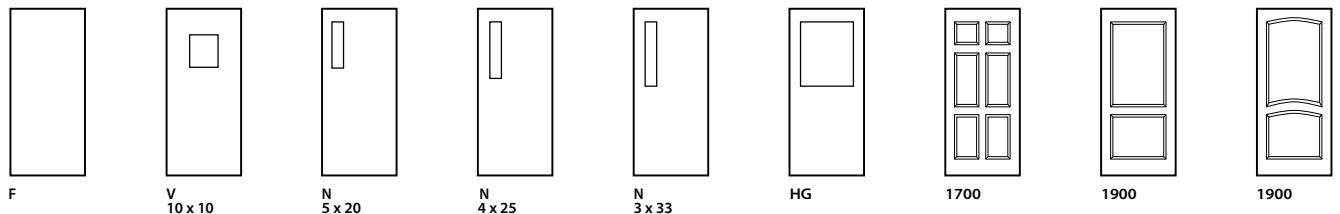
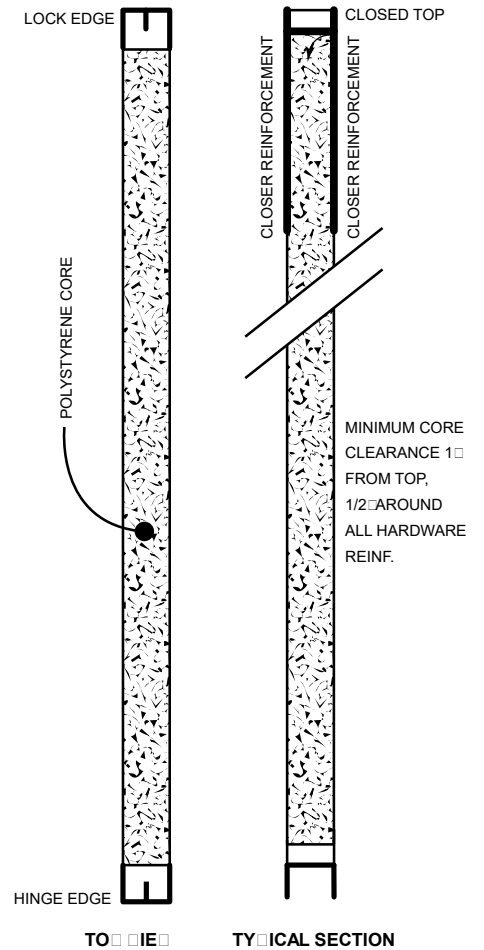



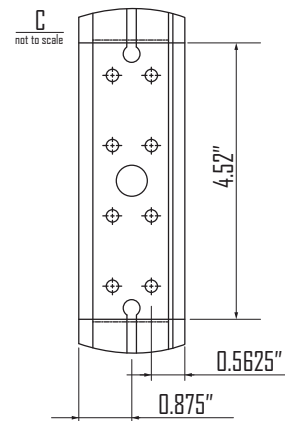
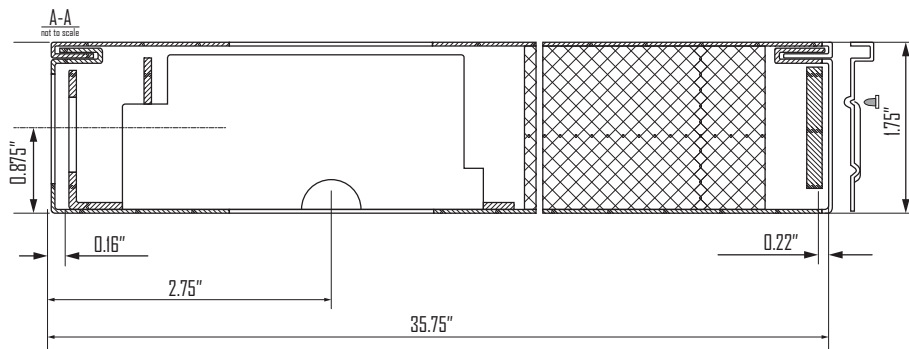
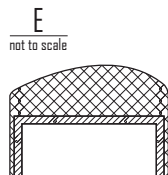
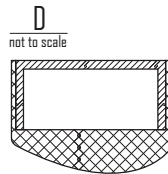
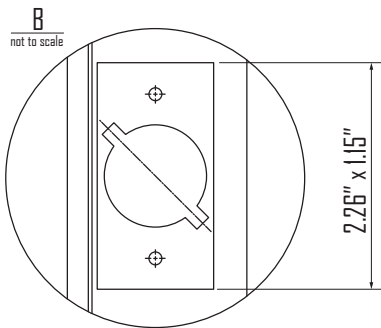
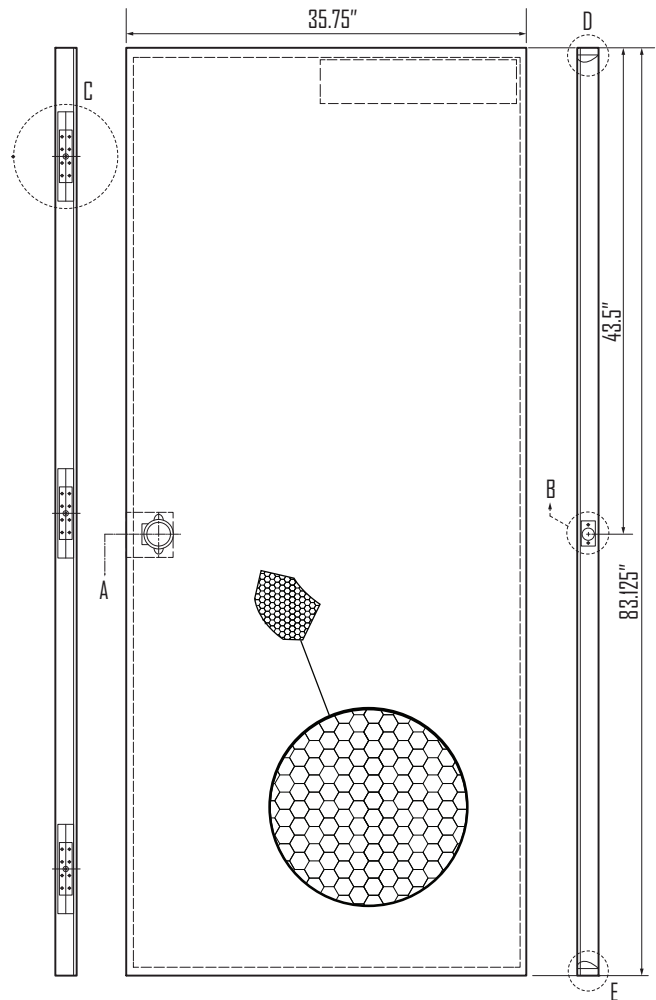

**Standard Features**

- ◆ 18 Gauge Cold Rolled Steel Doors
- ◆ Full Body Honeycomb Core
- ◆ Non-Handed Design
- ◆ 14-Gauge Closer Reinforcement
- ◆ 7-Gauge Hinge Reinforcement-Reversible
- ◆ 18-Gauge Flush Top Cap
- ◆ 18-Gauge Inverted Bottom Cap
- ◆ 14-Gauge Lock Reinforcement
- ◆ Powder Coated Prime - Grey, Factory Applied
- ◆ WHI 90-Minute Label



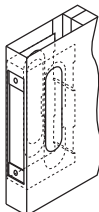
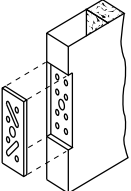
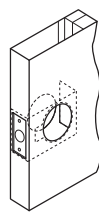
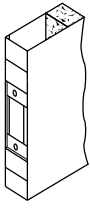
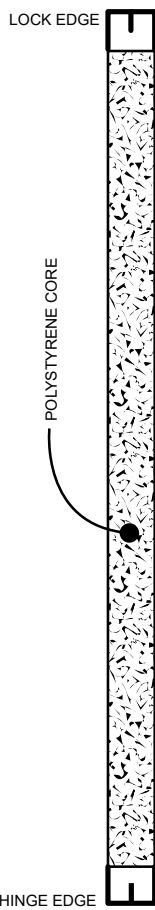

<p><b>Standard Features</b></p> <ul style="list-style-type: none"> <li>◆ 20-Gauge Cold Rolled or Galvanized Steel</li> <li>◆ Seamless Filled Edges</li> <li>◆ Full Body Polystyrene Core</li> <li>◆ Non- Handed Design</li> <li>◆ 12-Gauge Closer Reinforcement</li> <li>◆ 7-Gauge Hinge Reinforcement- Reversible</li> <li>◆ 16-Gauge Flush Top Cap - Galvanized Standard / Heavy Duty</li> <li>◆ 16-Gauge Inverted Bottom Cap - Galvanized</li> <li>◆ Prime Painted Grey Two Part Epoxy Factory Applied, Baked On</li> <li>◆ Standard Lock Preparations Include 161, Fed 86 Edge, Panic Bar Reinforced</li> <li>◆ WHI / ITS up to 3 hour, Positive Pressure and <input type="checkbox"/> Smoke included</li> <li>◆ Meets or Exceeds Standards for ANSI 250.4 and ANSI 250.8</li> </ul>	<p><b>Typical Hardware Preparations</b></p>  <p>ANSI / SDI A115.1 <input type="checkbox"/> MB <input type="checkbox"/> (MORTISE)</p>  <p>NON-HANDED HINGE</p>  <p>ANSI / SDI A115.2 <input type="checkbox"/> C <input type="checkbox"/> (BORED)</p>  <p>UNIVERSAL STRIKE A115.1 <input type="checkbox"/> U <input type="checkbox"/></p>	<p><b>Sections</b></p>  <p>LOCK EDGE</p>  <p>CLOSED TOP</p> <p>POLYSTYRENE CORE</p> <p>CLOSER REINFORCEMENT</p> <p>CLOSER REINFORCEMENT</p> <p>MINIMUM CORE CLEARANCE 1" FROM TOP, 1/2" AROUND ALL HARDWARE REINF.</p> <p>HINGE EDGE</p> <p>TO <input type="checkbox"/> IE <input type="checkbox"/></p> <p>TY <input type="checkbox"/> ICAL SECTION</p>
--	--	---

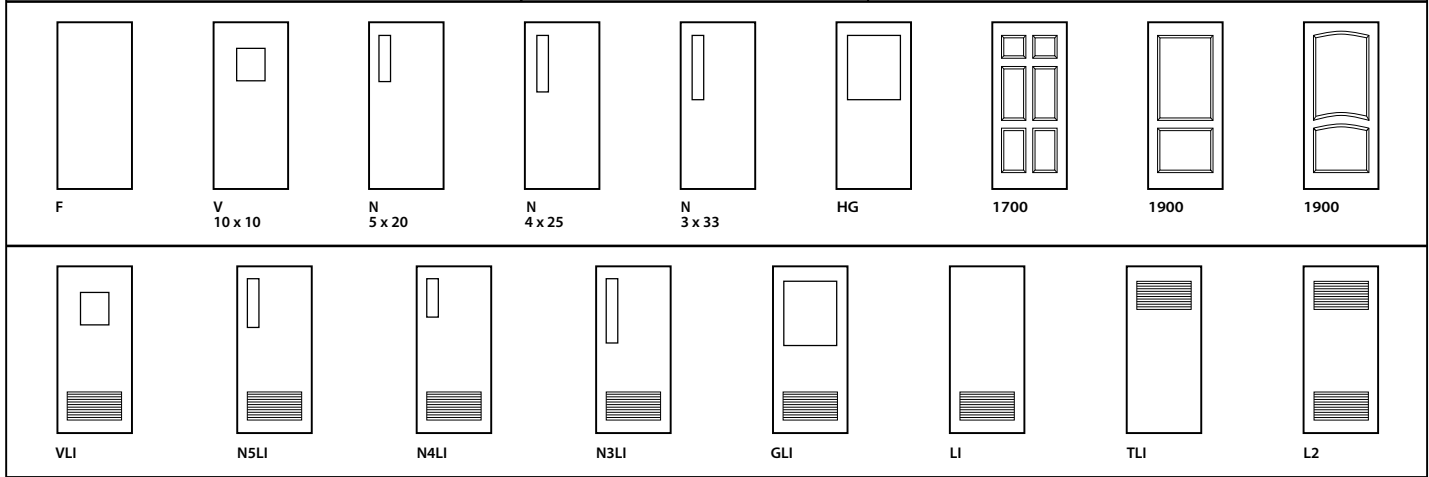



**Standard Features**

- ◆ 18-Gauge Galvanized Steel
- ◆ Seamless Filled Edges
- ◆ 22 Gauge Vertical Stiffeners on 6-inch Centers Hat Shaped
- ◆ Fiberglass Insulation Filled Cavities 1-5/8" thick 1.5 lb.cu.ft
- ◆ Beveled Strike Edge, Square Hinge Edge
- ◆ 7-Gauge Hinge Reinforcement- Standard / Heavy Duty Design
- ◆ 16-Gauge Top Cap
- ◆ 16-Gauge Inverted Bottom Cap
- ◆ 14-Gauge Lock Reinforcement
- ◆ 12-Gauge Closer Reinforcement
- ◆ Prime Painted Grey Two Part Epoxy Factory Applied, Baked On
- ◆ Standard Lock Preparations Include 161, Fed 86 Edge, Panic Bar Reinforced
- ◆ Approved for Double Egress Use
- ◆ WHI / ITS up to 3 hour, Positive Pressure and "S" Smoke included
- ◆ Meets or Exceeds Standards for ANSI 240.4 and ANSI 250.8

**Sections**

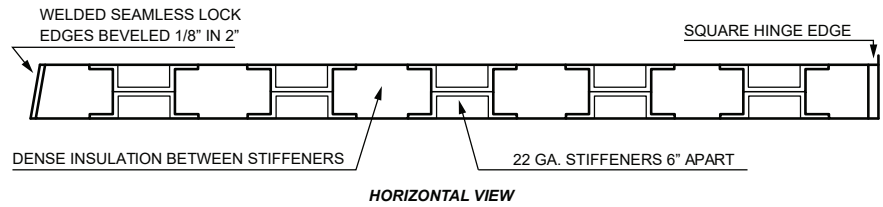

**Typical Hardware Preparations**

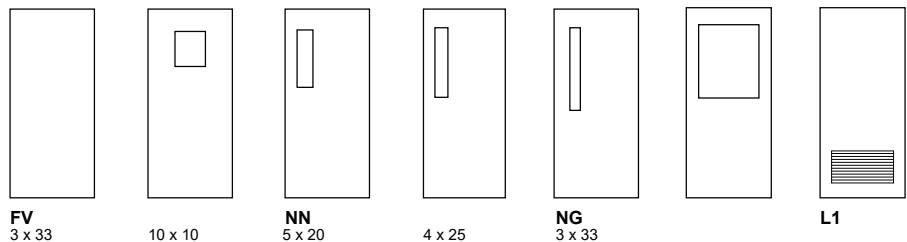
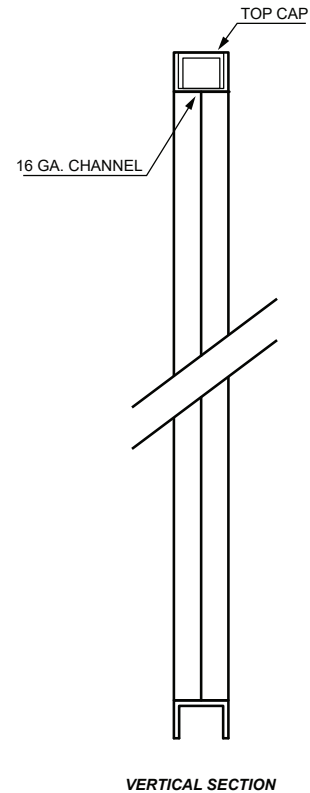
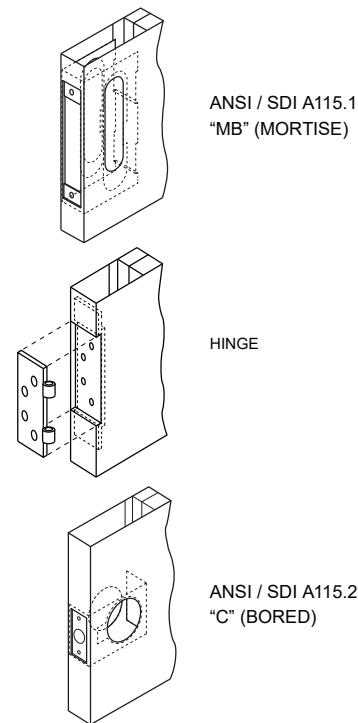



**Standard Features**

- ◆ 16-Gauge Galvanized Steel
- ◆ Seamless Filled Edges
- ◆ 22 Gauge Vertical Stiffeners on 6-inch Centers Hat Shaped
- ◆ Fiberglass Insulation Filled Cavities 1-5/8" thick 1.5 lb.cu.ft
- ◆ Beveled Strike Edge, Square Hinge Edge
- ◆ 7-Gauge Hinge Reinforcement- Standard / Heavy Duty Design
- ◆ 16-Gauge Top Cap
- ◆ 16-Gauge Inverted Bottom Cap
- ◆ 14-Gauge Lock Reinforcement
- ◆ 12-Gauge Closer Reinforcement
- ◆ Prime Painted Grey Two Part Epoxy Factory Applied, Baked On
- ◆ Standard Lock Preparations Include 161, Fed 86 Edge, Panic Bar Reinforced
- ◆ Approved for Double Egress Use
- ◆ WHI / ITS up to 3 hour, Positive Pressure and "S" Smoke included
- ◆ Meets or Exceeds Standards for ANSI 240.4 and ANSI 250.8

**Sections**

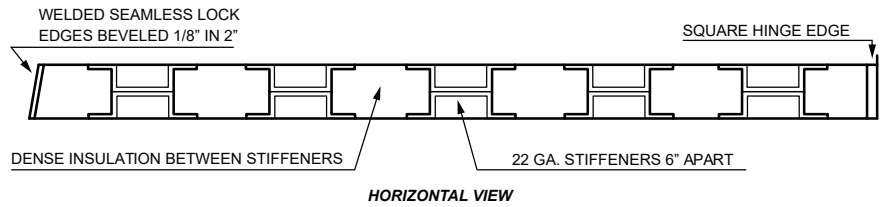

**Typical Hardware Preparations**

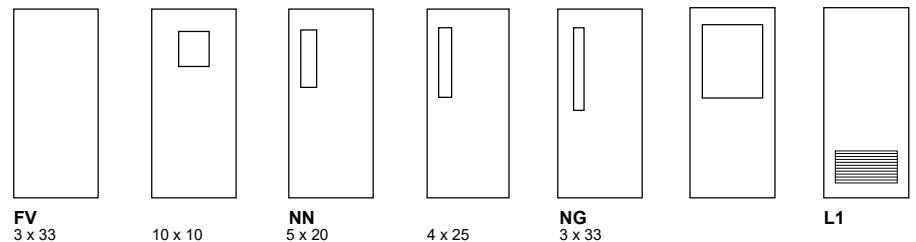
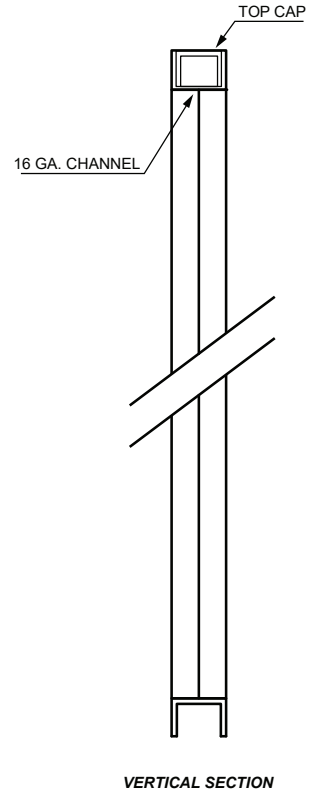
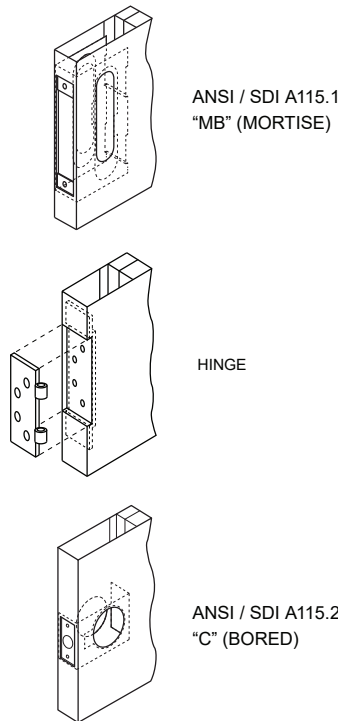



**Standard Features**

- ◆ 14 Gauge Door
- ◆ 12 Gauge Frame
- ◆ 161 Prep and 3 Deadbolt Preps
- ◆ Polystyrene Core
- ◆ 2-3/4" Backset
- ◆ 3/8" Undercut
- ◆ 4-1/2" x 4-1/2" Heavy Duty Hinge Prep
- ◆ DKS Steel Door & Frame Locations

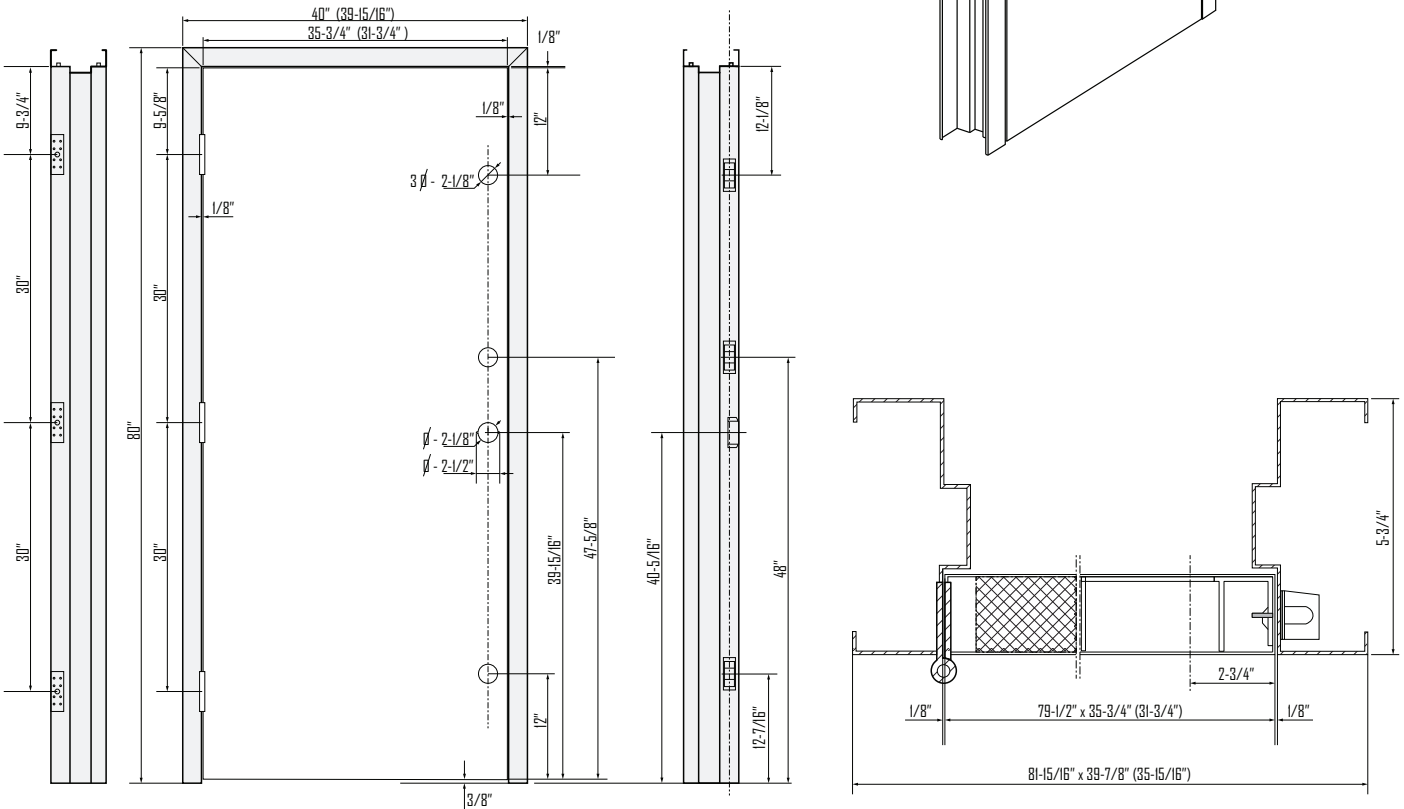
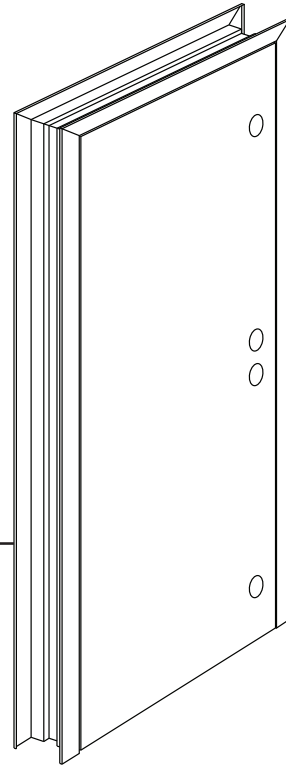





**Standard Features**

- ◆ 16 and 18 Gauge Doors
- ◆ Cold Rolled or Galvanized Steel
- ◆ Tight Corner Seam
- ◆ Full Body Polystyrene Core
- ◆ Non-Handed Design
- ◆ 12-Gauge Closer Reinforcement
- ◆ Continuous 7-Gauge Channel Hinge Reinforcement Set at Heavy Duty Depth - Full Height
- ◆ 14-Gauge, 10-inch Lock Face Reinforcements
- ◆ 16-Gauge Flush Top Cap
- ◆ 16-Gauge Inverted Bottom Cap
- ◆ Prime Painted Grey Two Part Epoxy Factory Applied, Baked On
- ◆ Remove Skin at Desired Locations for Hinge Size - Template, Drill and Tap, Apply Reversible Hinge Shim

**Door Construction Reinforcement Detail**

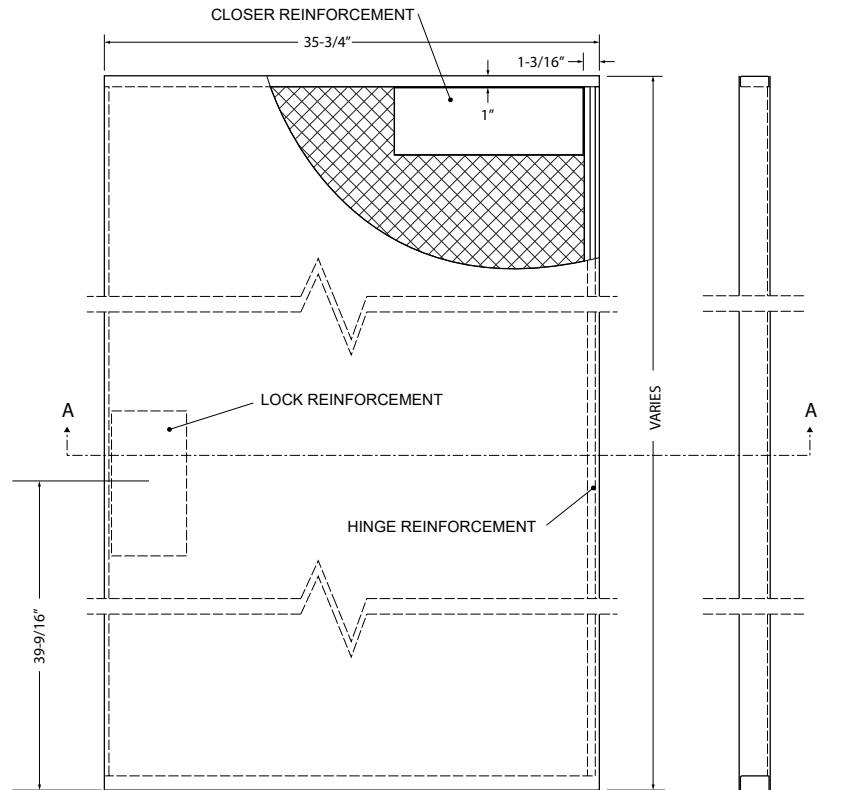

SECTION A-A

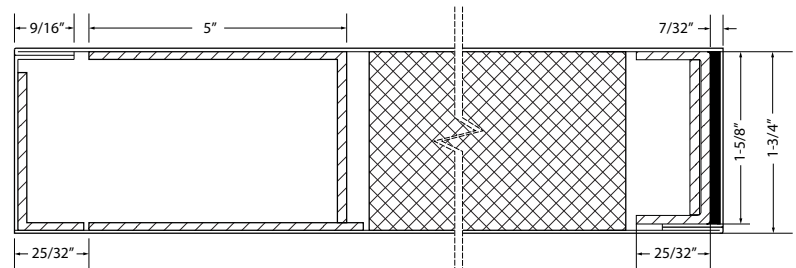

ILLUSTRATION NOT TO SCALE





**Standard Features**

- ◆ 16-Gauge Cold Rolled or Galvanized Steel
- ◆ Seamless Filled Edges
- ◆ Full Body Polystyrene Core
- ◆ Non- Handed Design
- ◆ 12-Gauge Closer Reinforcement
- ◆ 7-Gauge Hinge Reinforcement- Reversible
- ◆ 16-Gauge Flush Top Cap - Galvanized Standard / Heavy Duty
- ◆ 16-Gauge Inverted Bottom Cap - Galvanized
- ◆ Prime Painted Grey Two Part Epoxy Factory Applied, Baked On
- ◆ Standard Lock Preparations Include 161, Fed 86 Edge, Panic Bar Reinforced
- ◆ WHI / ITS up to 3 hour, Positive Pressure and  S  Smoke included
- ◆ Meets or Exceeds Standards for ANSI 250.4 and ANSI 250.8

**Typical Hardware Preparations**

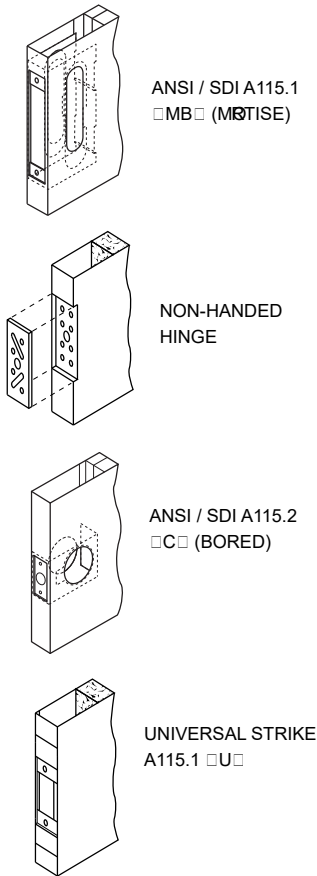

**Sections**

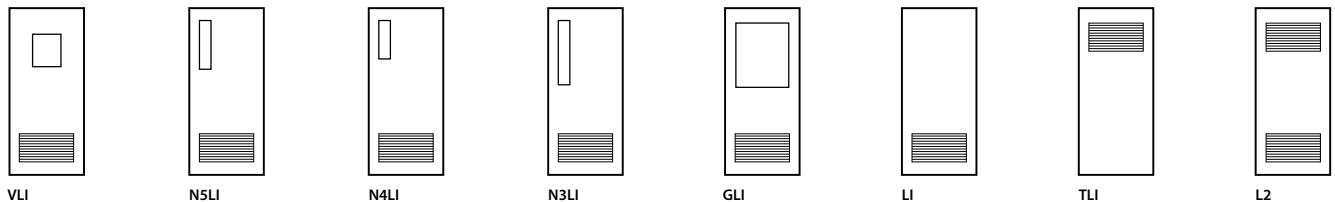
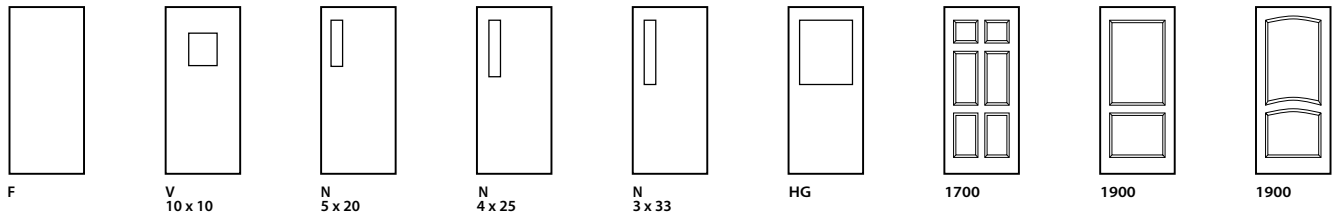
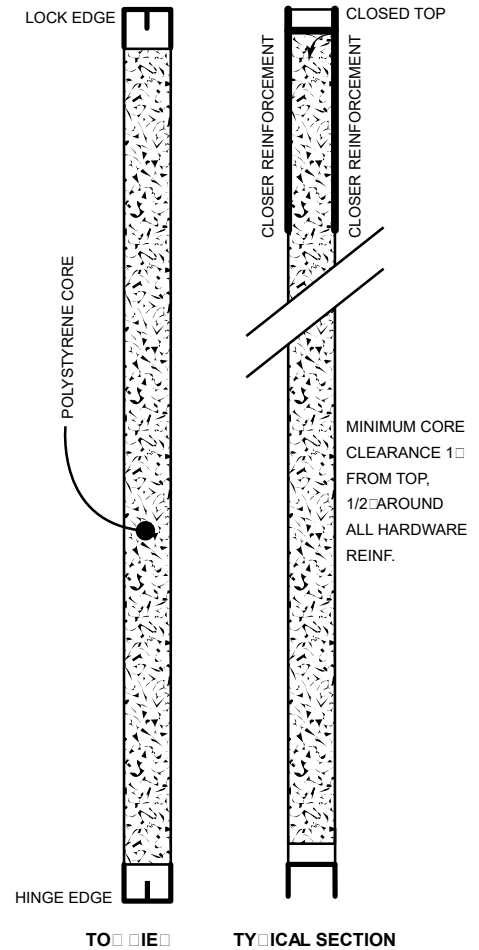



**Standard Features**

- ◆ 18 and 20 Gauge Cold Rolled or Galvanized Steel
- ◆ Seamless Filled Edges
- ◆ Full Body Polystyrene Core
- ◆ Non-Handed Design
- ◆ 12-Gauge Closer Reinforcement
- ◆ 7-Gauge Hinge Reinforcement- Standard / Heavy Duty
- ◆ 16-Gauge Flush Top Cap - Galvanized
- ◆ 16-Gauge Inverted Bottom Cap - Galvanized
- ◆ ADA 10 inch Minimum Bottom Rail
- ◆ Prime Painted Grey Two Part Epoxy Factory Applied, Baked On
- ◆ Standard Lock Preparations Include 161, Fed 86 Edge, Panic Bar Reinforced
- ◆ WHI / ITS up to 3 hour, Positive Pressure and  Smoke included
- ◆ STC Rated 28, Model 32-1700 STC Rated 32
- ◆ Meets or Exceeds Standards for ANSI 250.4 and ANSI 250.8

**Typical Hardware Preparations**

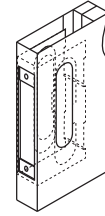

ANSI / SDI A115.1  
 MB (MORTISE)

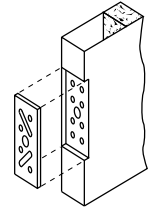

NON-HANDED HINGE

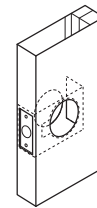

ANSI / SDI A115.2  
 C (BORED)

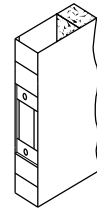

UNIVERSAL STRIKE A115.1  U

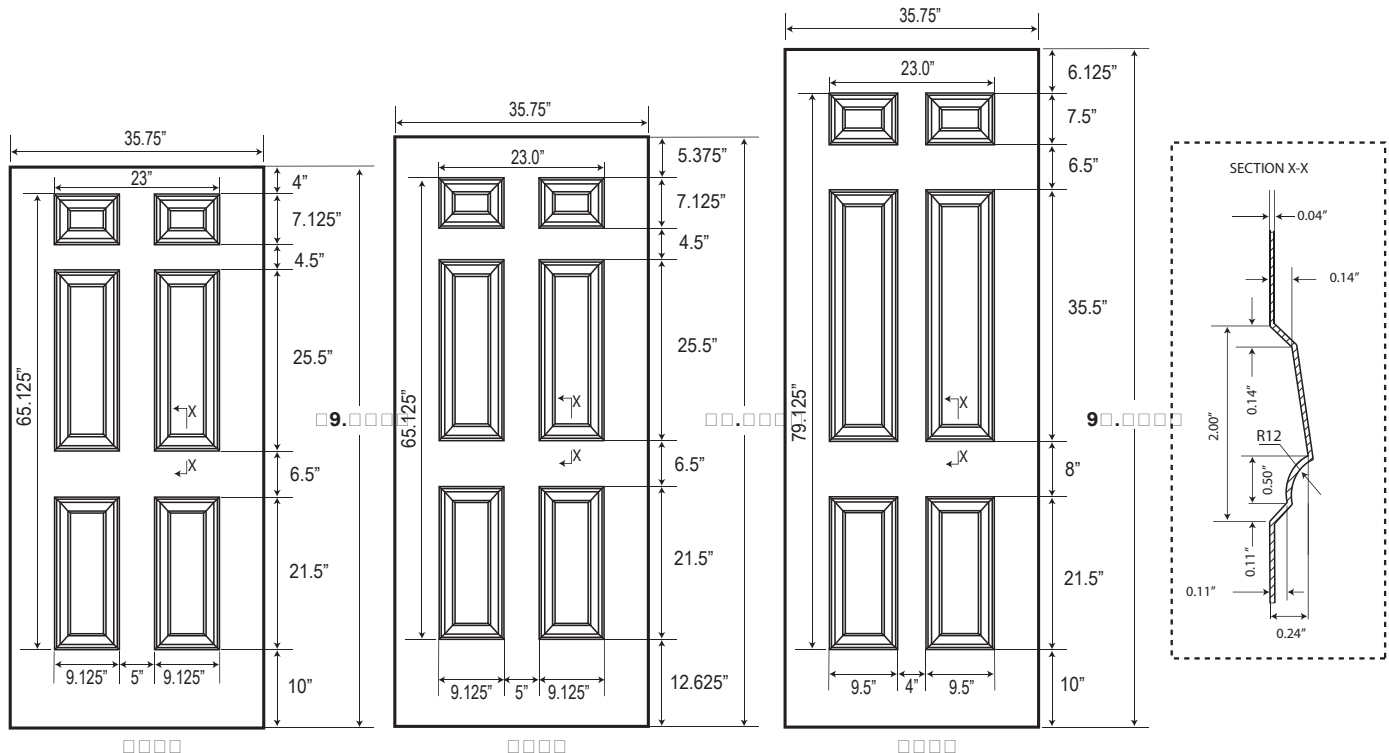



**Standard Features**

- ◆ 18 and 16 Gauge Cold Rolled or Galvanized Steel
- ◆ Seamless Filled Edges
- ◆ Polystyrene Core
- ◆ 7-Gauge Hinge Reinforcement - Reversible
- ◆ 16-Gauge Flush Top Cap - Galvanized
- ◆ 16-Gauge Inverted Bottom Cap - Galvanized
- ◆ Concealed Vertical Rod Top & Bottom Reinforcement Prepared
- ◆ WHI / ITS up to 3 hours, Positive Pressure and S-Smoke included
- ◆ Meets or Exceeds Standards for ANSI 250.4 and ANSI 250.8
- ◆ Prime Painted Grey Two Part Epoxy Factory Applied, Baked On

**Typical Hardware Preparations**

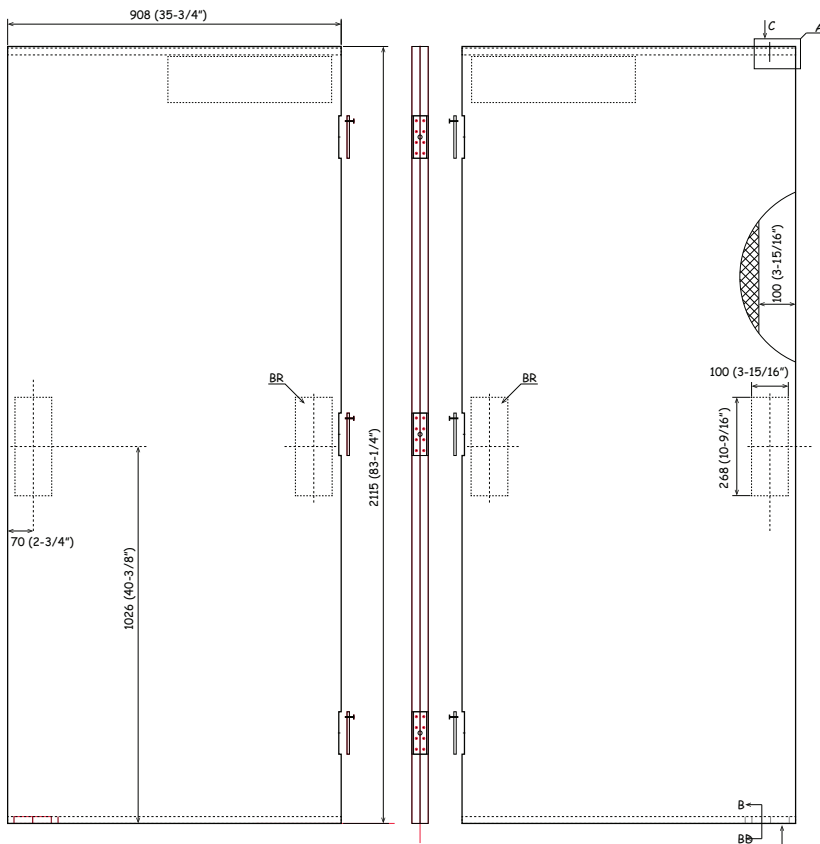
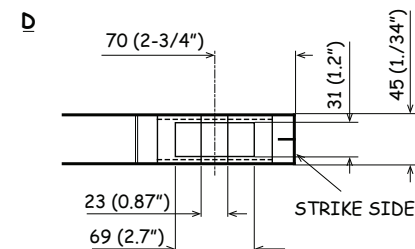
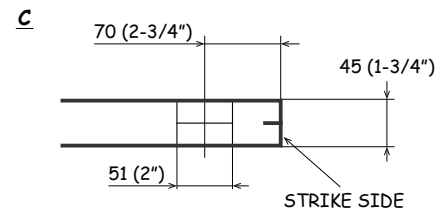
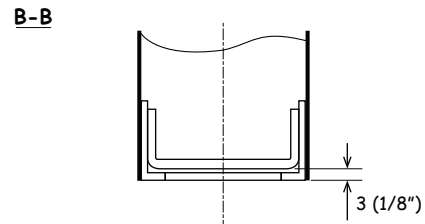
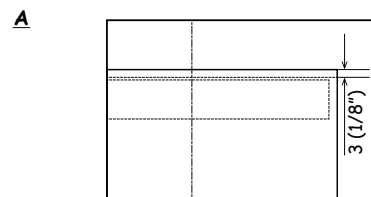
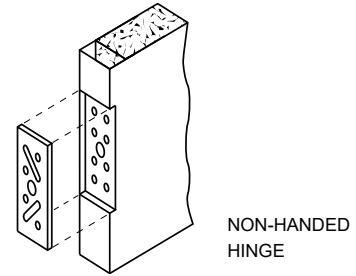

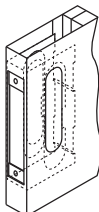
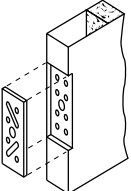
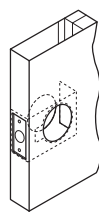
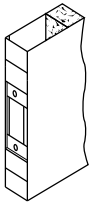
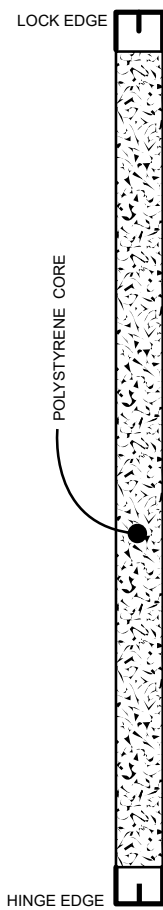
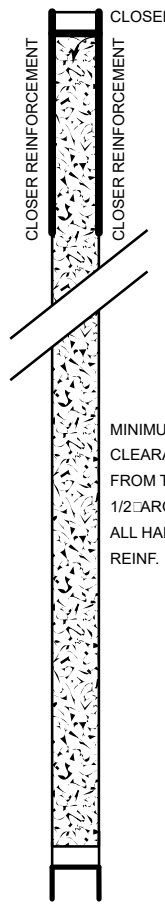

<p><b>Standard Features</b></p> <ul style="list-style-type: none"> <li>◆ 18-Gauge Cold Rolled or Galvanized Steel</li> <li>◆ Seamless Filled Edges</li> <li>◆ Full Body Polystyrene Core</li> <li>◆ Non- Handed Design</li> <li>◆ 12-Gauge Closer Reinforcement</li> <li>◆ 7-Gauge Hinge Reinforcement- Reversible</li> <li>◆ 16-Gauge Flush Top Cap - Galvanized Standard / Heavy Duty</li> <li>◆ 16-Gauge Inverted Bottom Cap - Galvanized</li> <li>◆ Prime Painted Grey Two Part Epoxy Factory Applied, Baked On</li> <li>◆ Standard Lock Preparations Include 161, Fed 86 Edge, Panic Bar Reinforced</li> <li>◆ WHI / ITS up to 3 hour, Positive Pressure and <input type="checkbox"/> S <input type="checkbox"/> Smoke included</li> <li>◆ Meets or Exceeds Standards for ANSI 250.4 and ANSI 250.8</li> </ul>	<p><b>Typical Hardware Preparations</b></p>  <p>ANSI / SDI A115.1 <input type="checkbox"/> MB <input type="checkbox"/> (MORTISE)</p>  <p>NON-HANDED HINGE</p>  <p>ANSI / SDI A115.2 <input type="checkbox"/> C <input type="checkbox"/> (BORED)</p>  <p>UNIVERSAL STRIKE A115.1 <input type="checkbox"/> U <input type="checkbox"/></p>	<p><b>Sections</b></p>  <p>LOCK EDGE HINGE EDGE POLYSTYRENE CORE TO <input type="checkbox"/> IE <input type="checkbox"/></p>  <p>CLOSED TOP CLOSER REINFORCEMENT MINIMUM CORE CLEARANCE 1" FROM TOP, 1/2" AROUND ALL HARDWARE REINF. TY <input type="checkbox"/> ICAL SECTION</p>
---	--	---

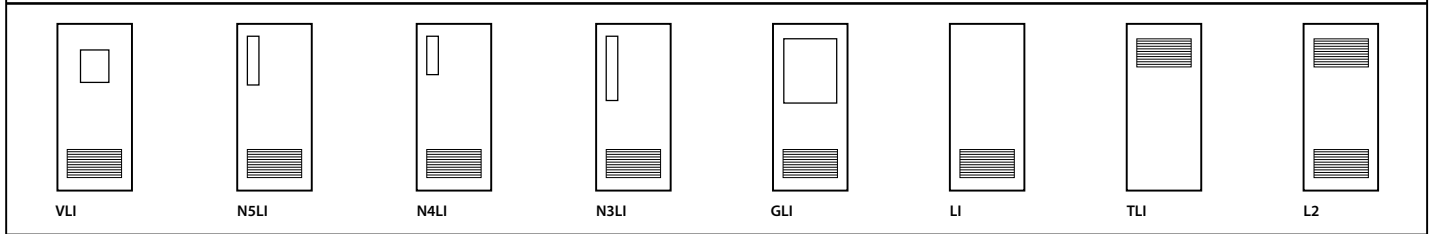
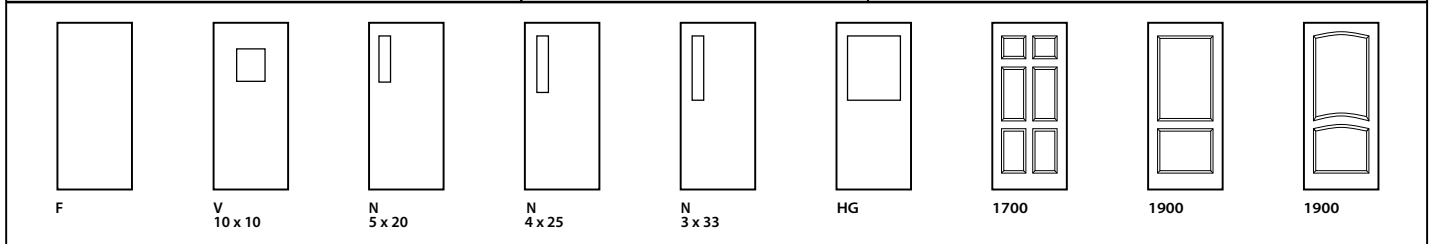



**Standard Features**

- ◆ 18 Gauge Cold Rolled or Galvanized Steel
- ◆ Seamless Filled Edges
- ◆ Full Body Polystyrene Core
- ◆ Non-Handed Design
- ◆ 12-Gauge Closer Reinforcement
- ◆ 7-Gauge Hinge Reinforcement- Standard / Heavy Duty
- ◆ 16-Gauge Flush Top Cap - Galvanized
- ◆ 16-Gauge Inverted Bottom Cap - Galvanized-
- ◆ ADA 10 inch Minimum Bottom Rail
- ◆ Prime Painted Grey Two Part Epoxy Factory Applied, Baked On
- ◆ Standard Lock Preparations Include 161, 161-DL, Fed 86 Edge, Panic Bar Reinforcement
- ◆ WHI / ITS up to 3 hour, Positive Pressure and "S" Smoke included
- ◆ STC Rated 28, Model 32-1900  
STC Rated 32
- ◆ Meets or Exceeds Standards for ANSI 250.4 and ANSI 250.8

**Typical Hardware Preparations**

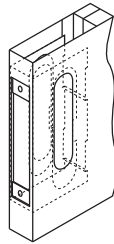

ANSI / SDI A115.1  
□ MB □ (MORTISE)

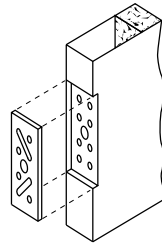

NON-HANDED  
HINGE

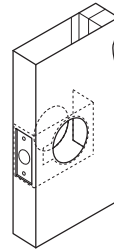

ANSI / SDI A115.2  
□ C □ (BORED)

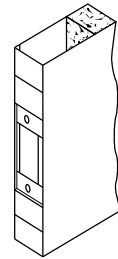

UNIVERSAL STRIKE  
A115.1 □ U □

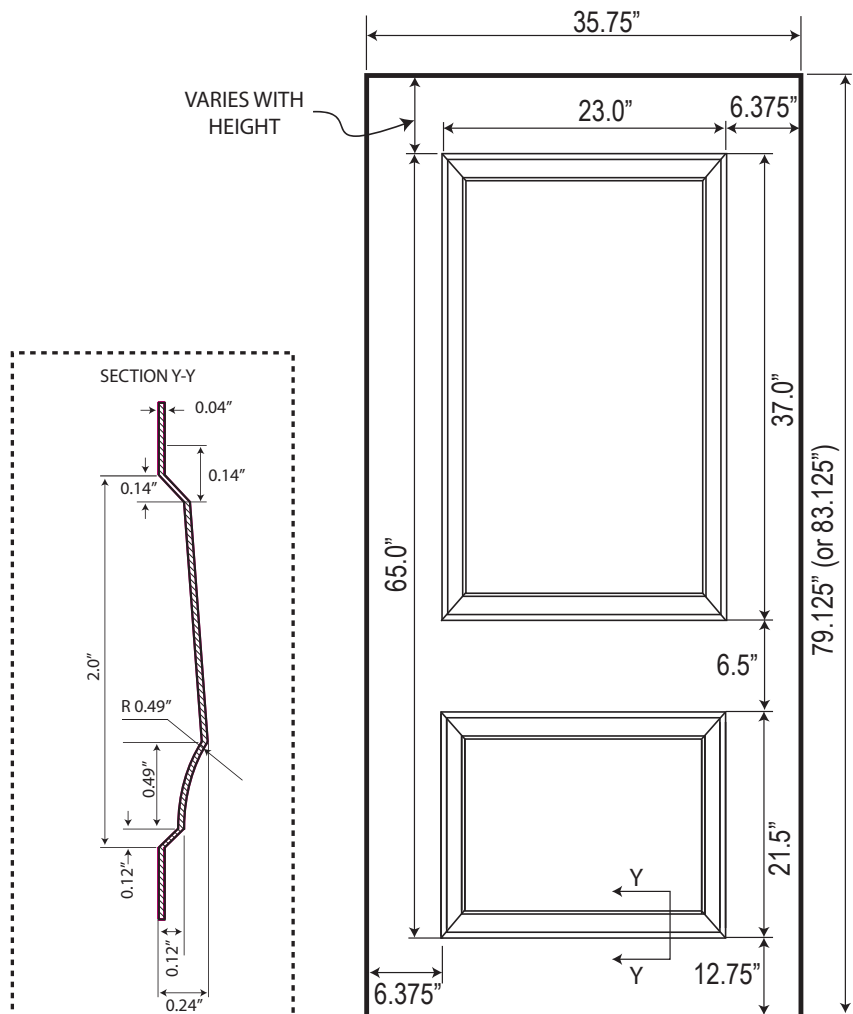



**Standard Features**

- ◆ 18 Gauge Cold Rolled or Galvanized Steel
- ◆ Seamless Filled Edges
- ◆ Full Body Polystyrene Core
- ◆ Non-Handed Design
- ◆ 12-Gauge Closer Reinforcement
- ◆ 7-Gauge Hinge Reinforcement- Standard / Heavy Duty
- ◆ 16-Gauge Flush Top Cap - Galvanized
- ◆ 16-Gauge Inverted Bottom Cap - Galvanized
- ◆ ADA 10 inch Minimum Bottom Rail
- ◆ Prime Painted Grey Two Part Epoxy Factory Applied, Baked On
- ◆ Standard Lock Preparations Include 161, 161-DL, Fed 86 Edge, Panic Bar Reinforcement
- ◆ WHI / ITS up to 3 hour, Positive Pressure and   Smoke included
- ◆ STC Rated 28, Model 32-1900 STC Rated 32
- ◆ Meets or Exceeds Standards for ANSI 250.4 and ANSI 250.8

**Typical Hardware Preparations**

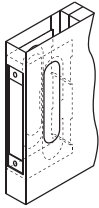

ANSI / SDI A115.1  
 MB (MORTISE)

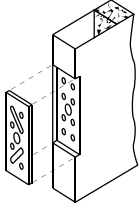

NON-HANDED HINGE

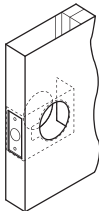

ANSI / SDI A115.2  
 C (BORED)

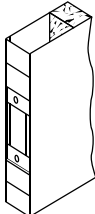

UNIVERSAL STRIKE  
A115.1

SECTION Y-Y

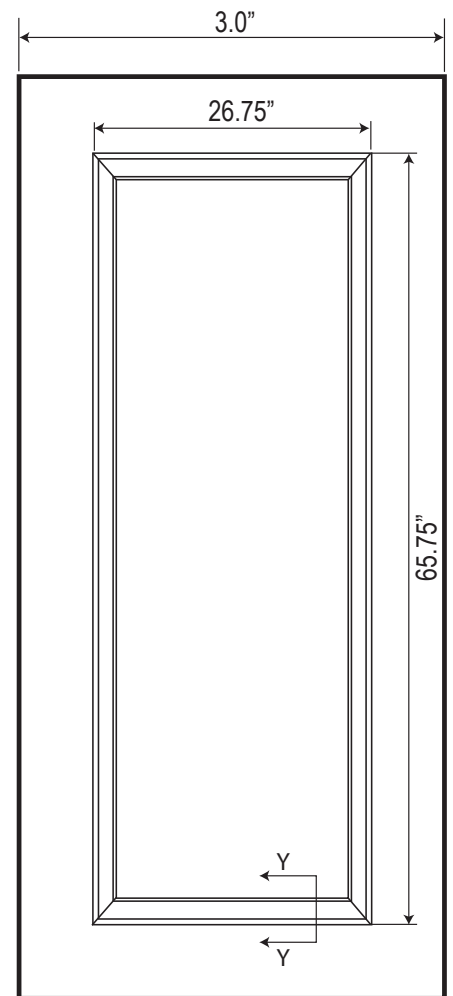
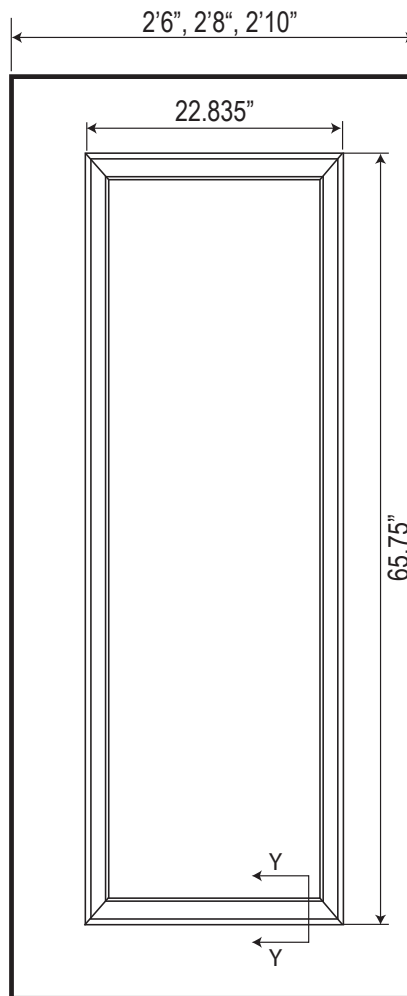
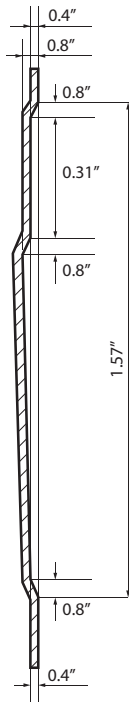



**Standard Features**

- ◆ 18/16 Gauge Cold Rolled or Galvanized Steel
- ◆ Seamless Filled Edges
- ◆ Full Body Honeycomb Core #90 Density Weight
- ◆ Non Handed Design
- ◆ 12 Gauge Closer Reinforcement
- ◆ 7-Gauge Hinge Reinforcement-Reversible
- ◆ 16-Gauge Top Cap - Galvanized
- ◆ 16-Gauge Inverted Bottom Cap - Galvanized
- ◆ Hardware Reinforced for 161, Fed 86 Edge, Panic Bar Application
- ◆ Prime Painted Grey Two Part Epoxy Factory Applied, Baked On
- ◆ WHI / ITS up to 3 hour, Positive Pressure and "S" Smoke included
- ◆ Meets or Exceeds Standards for ANSI 240.4 and ANSI 250.8

**Sections**

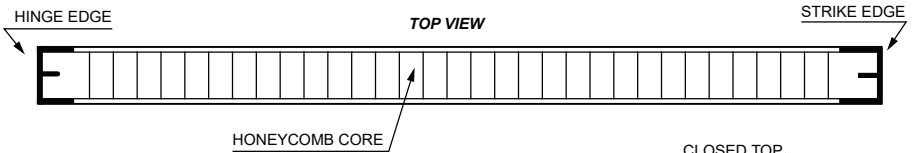

**Typical Hardware Preparations**

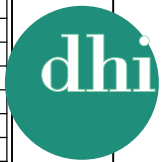
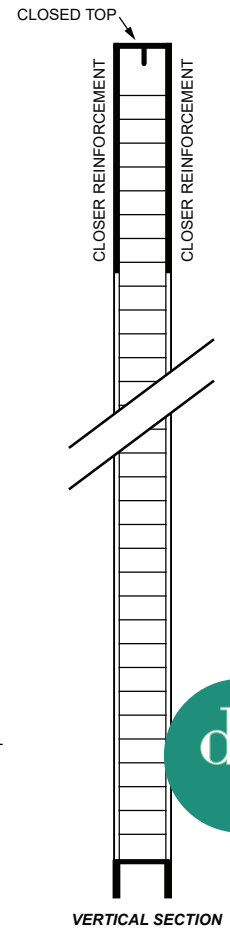
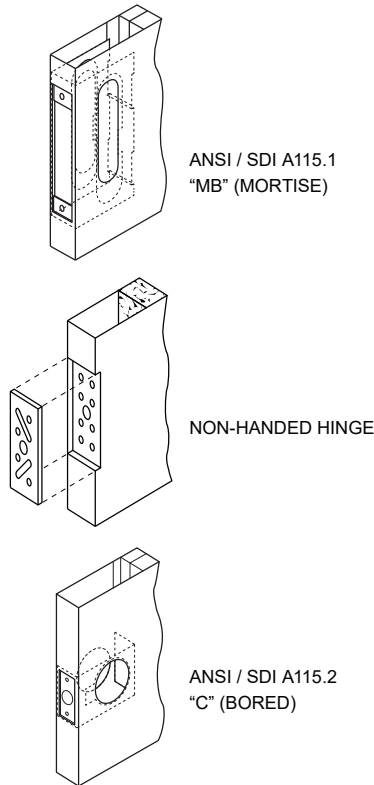

**3 HR. LABEL STYLES**

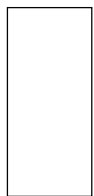

**FV**  
3 x 33

**1-1/2 HR. LABEL STYLES**

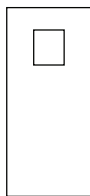

10 x 10

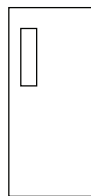

**NN**  
5 x 20

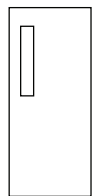

4 x 25

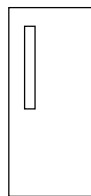

**NG**  
3 x 33

**3/4 HR. LABEL STYLES**

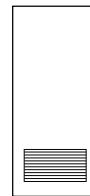
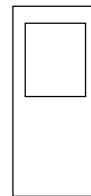

**L1**







**Standard Features**

- ◆ 18-Gauge Galvanized Steel or Cold Rolled Steel
- ◆ Seamless Filled Edges
- ◆ Full Body Polystyrene Core
- ◆ Handed Design
- ◆ 12-Gauge Closer Reinforcement
- ◆ 7-Gauge Hinge Reinforcement- Reversible
- ◆ 16-Gauge Flush Top Cap - Galvanized Standard / Heavy Duty
- ◆ 16-Gauge Inverted Bottom Cap - Galvanized
- ◆ Prime Painted Grey Two Part Epoxy Factory Applied, Baked On
- ◆ Standard Lock Preparations Include 161, Panic Bar Reinforced
- ◆ WHI / ITS up to 3 hour, Positive Pressure and "S" Smoke included
- ◆ Meets or Exceeds Standards for ANSI 250.4 and ANSI 250.8

**Sections**

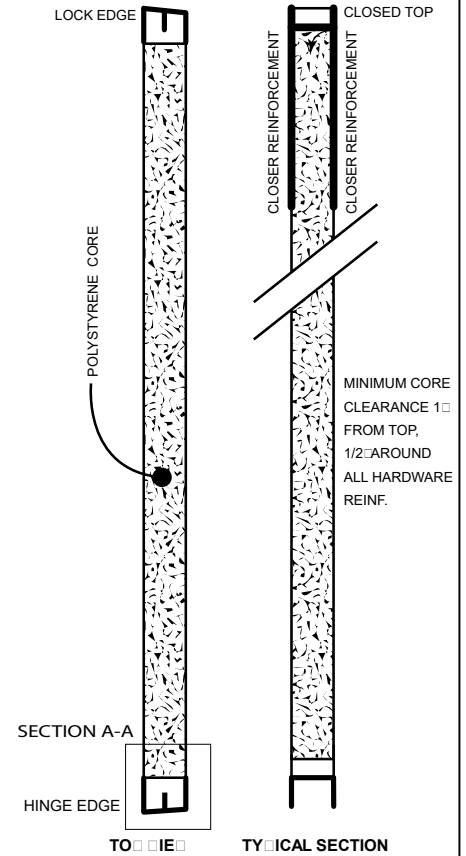
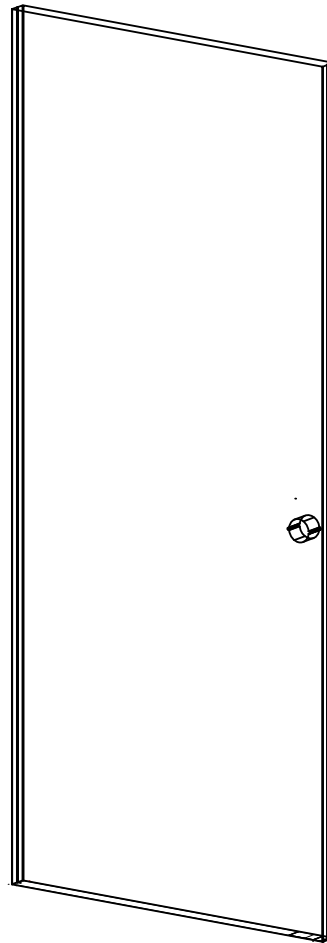

**Typical Hardware Preparations**

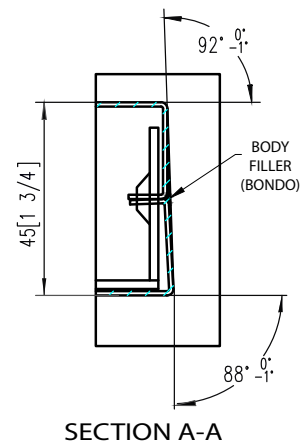
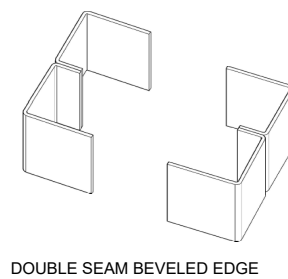
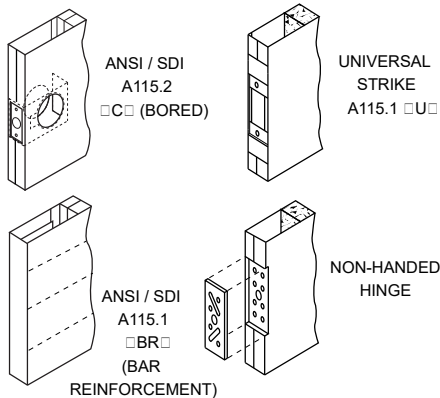



**Standard Features**

- ◆ 18/16 Gauge Cold Rolled or Galvanized Steel
- ◆ Seamless Filled Edges
- ◆ Full Body Honeycomb Core #90 Density Weight
- ◆ Non Handed Design
- ◆ 12 Gauge Closer Reinforcement
- ◆ 7-Gauge Hinge Reinforcement- Reversible
- ◆ 16-Gauge Top Cap - Galvanized
- ◆ 16-Gauge Inverted Bottom Cap - Galvanized
- ◆ Reinforced for Double Egress Surface Vertical Rod Application
- ◆ Prime Painted Grey Two Part Epoxy Factory Applied, Baked On
- ◆ WHI / ITS up to 3 hour, Positive Pressure and "S" Smoke included
- ◆ Meets or Exceeds Standards for ANSI 240.4 and ANSI 250.8

**Sections**

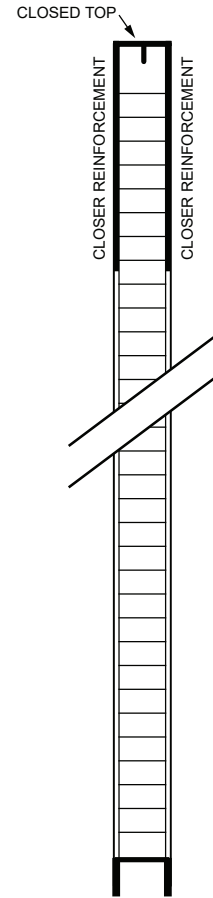
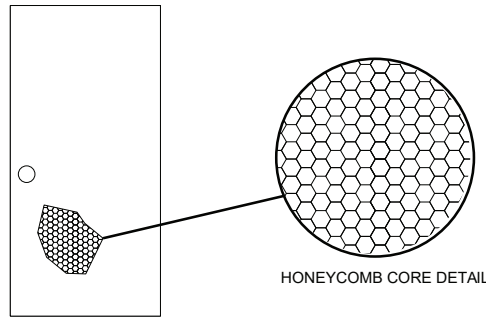
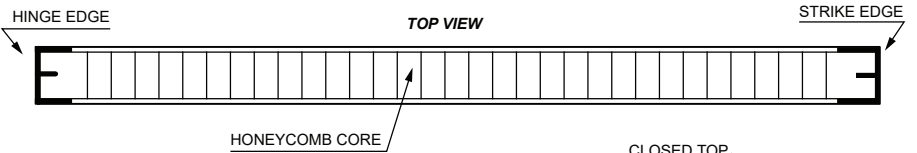

**Typical Hardware Preparation**

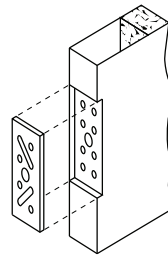

NON-HANDED HINGE

VERTICAL SECTION

**3 HR. LABEL STYLES**



**FV**  
3 x 33

**1-1/2 HR. LABEL STYLES**

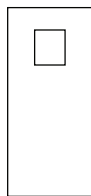

10 x 10

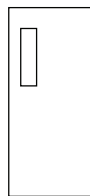

**NN**  
5 x 20

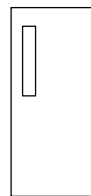

4 x 25

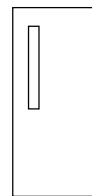

**NG**  
3 x 33

**3/4 HR. LABEL STYLES**

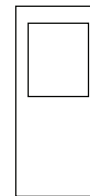

**L1**

Warnock Hersey





**Standard Features**

- ◆ 1-3/4" Temperature Rise Doors 250 or 450
- ◆ 18 or 16 Gauge Cold Rolled or Galvanized Steel
- ◆ Seamless Filled Edges
- ◆ Full Body Mineral Core
- ◆ Non- Handed Design
- ◆ 12-Gauge Closer Reinforcement
- ◆ 7-Gauge Hinge Reinforcement- Standard / Heavy Duty
- ◆ 16-Gauge Flush Top Cap - Galvanized
- ◆ 16-Gauge Inverted Bottom Cap - Galvanized
- ◆ Prime Painted Grey Two Part Epoxy Factory Applied, Baked On
- ◆ Standard Lock Preparations Include 161, Fed 86 Edge, Panic Bar Reinforced
- ◆ WHI / ITS up to 3 hour, Positive Pressure and Smoke included
- ◆ Meets or Exceeds Standards for ANSI 250.4 and ANSI 250.8

**Typical Hardware Preparations**

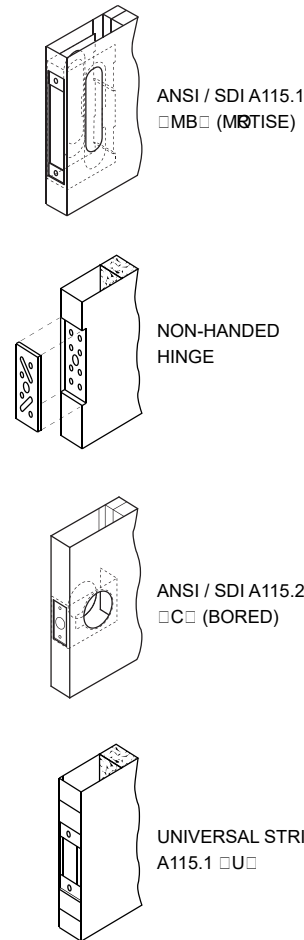

**Sections**

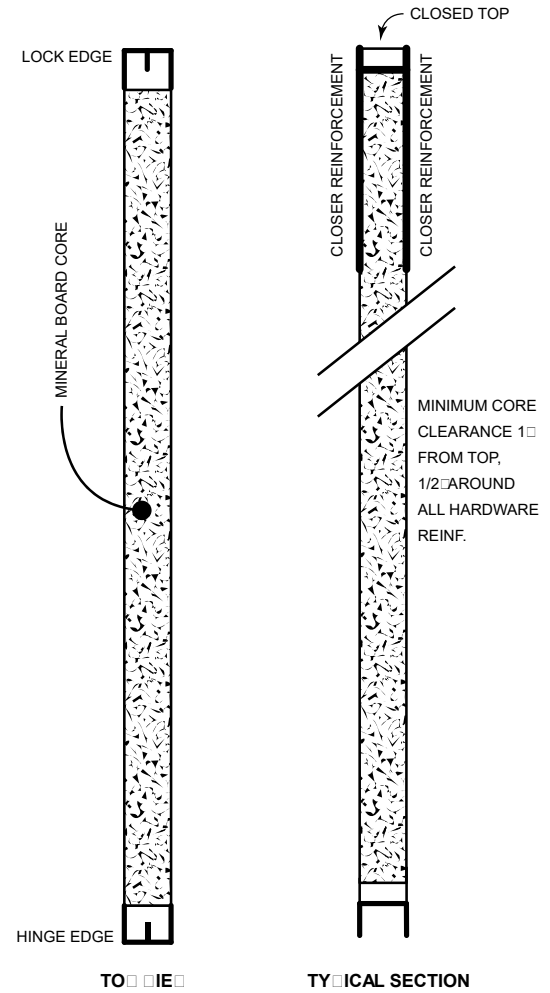

OTHER LAYOUT STYLES

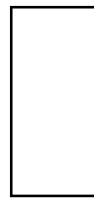

F

OTHER LAYOUT STYLES

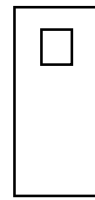

10 x 10

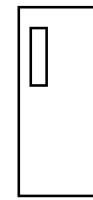

N 5 x 20

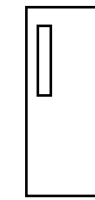

N 4 x 25

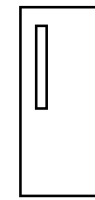

N 3 x 33





**Standard Features**

- ◆ 24-Gauge Cold Rolled Steel
- ◆ Honeycomb Core
- ◆ Non-Handed Design
- ◆ Reversible Residential Hinge  
4" x 4", gauge .097"
- ◆ Matches Timely's Residential Frame Hinge and Strike Locations
- ◆ Lock location 60" for 80" doors;  
44" for 6'8" doors x 2 3/8" backset  
with 1" x 1 1/4" Square Corner Face Plate
- ◆ Flush Top / Inverted Bottom
- ◆ Prime Paint Finish, Powder Coat
- ◆ Lock preparation (161) Cylindrical or  
Blank Reinforced (BR)
- ◆ Wood reinforced hinge and lock locations

**Typical Hardware Preparations**

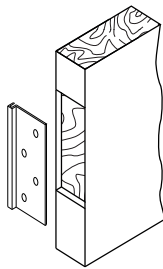

NON-HANDED HINGE

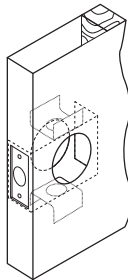

ANSI / SDI A115.2  
□ C □ (BORED)

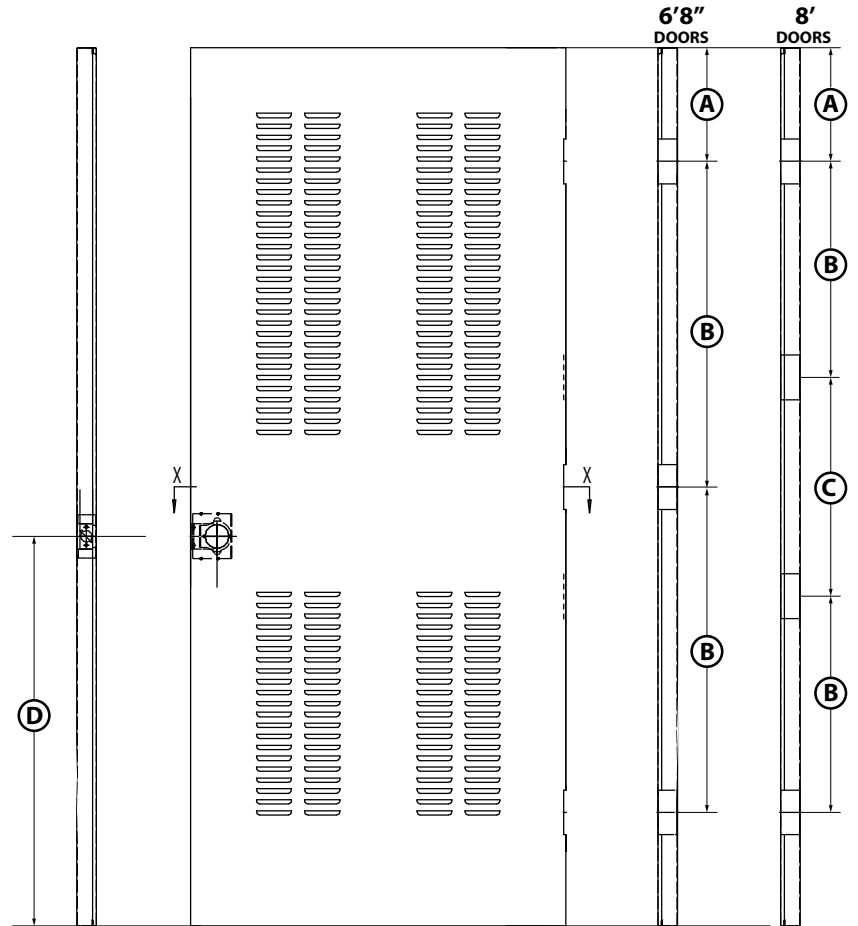

DOOR SIZE	A	□	C	D
6 □ 8 □	10.125 □	29.75 □	-----	35.125 □
8 □	10.125 □	25.0 □	25.5 □	35.125 □

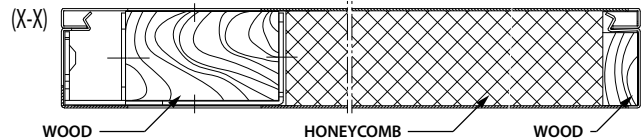



**Standard Features**

- ◆ 16-Gauge Cold Rolled Steel or A-40 Galvanized option
- ◆ Double Egress Profile
- ◆ Exact fit mitered corner
- ◆ 7-Gauge Hinge Reinforcement
- ◆ Standard / Heavy Duty Adjustment
- ◆ Floor Anchors in all jamb sides
- ◆ Wall anchors for Masonry, Wood Stud, Metal Stud and Strap Anchors
- ◆ 4-inch to 13-inch jamb depths
- ◆ 20-minute to 3-hour label

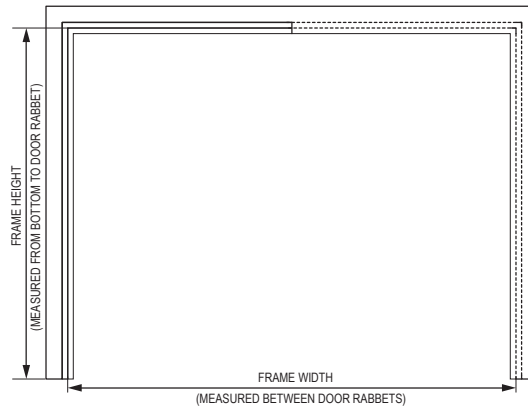
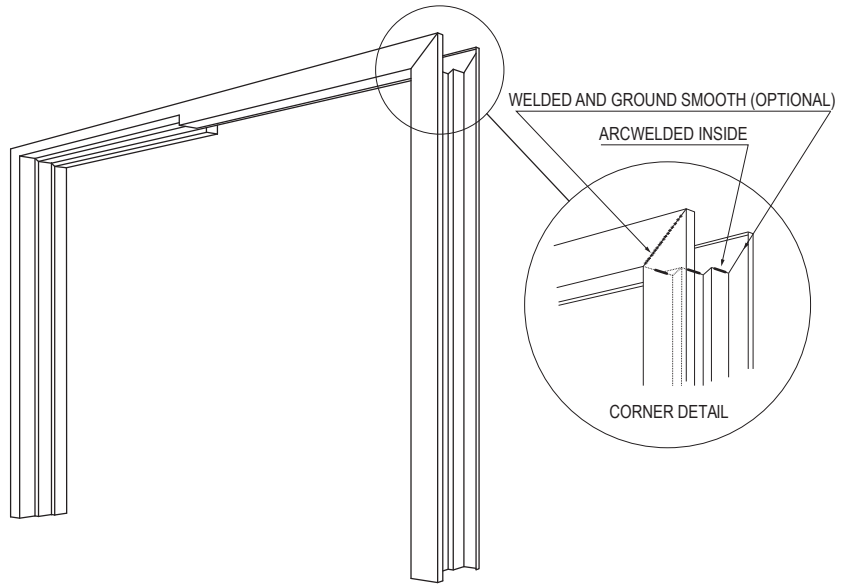

FRAMES PROVIDED RIGHT HAND EXCEPT AS NOTED

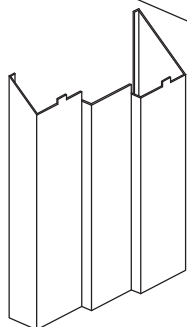
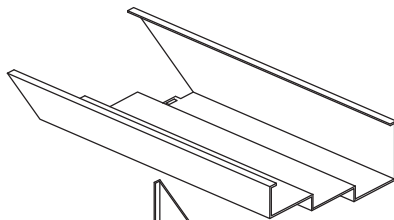
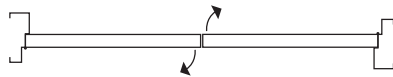

K-D CORNER DETAIL

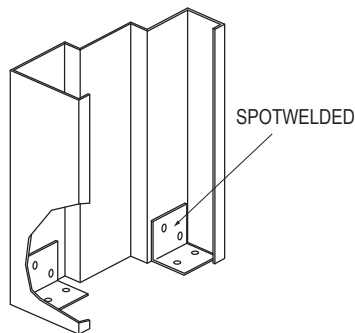

FLOOR ANCHOR DETAIL

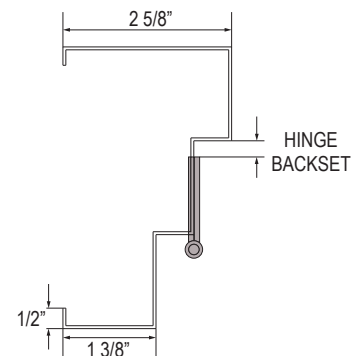



**Standard Features**

- ◆ 16-Gauge A-40 Galvanized Steel
- ◆ 3-Piece System Designed to Adjust to Multiple Depth Wall Conditions
- ◆ Slide Rails along the frame throat enables the frame to accommodate 4.75" to 7.875" thick walls
- ◆ Three 7-Gauge 4.5" x 4.5" Hinge Reinforcements for 6'8" and 7'0" Doors
- ◆ Four 7-Gauge 4.5" x 4.5" Hinge Reinforcements for 8' Doors
- ◆ Hinge Reinforcement Accepts Standard or Heavy Weight Template Hinges
- ◆ 12-Gauge ASA Strike Reinforcement
- ◆ Frame is Prepared for Silencer Operation
- ◆ 90 Minute WHI Mark as Standard

**Typical Hardware Preparations**

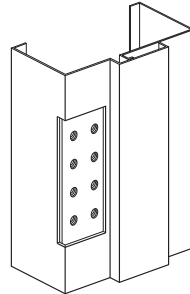

4-1/2" x 4-1/2"  
1-3/4" FRAME HINGE PREP

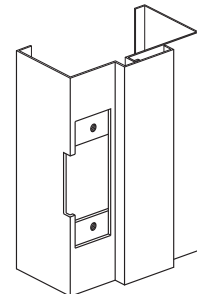

4-7/8" UNIVERSAL STRIKE

**Sections**

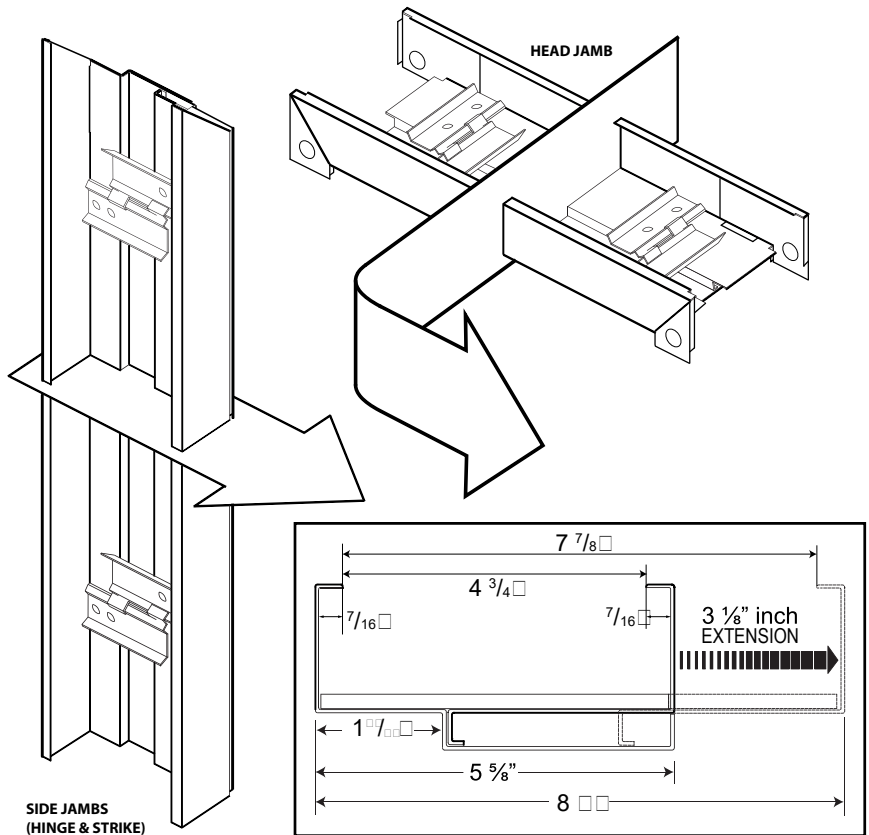



**Standard Features**

- ◆ 16-Gauge Cold Rolled or Galvanized Steel
- ◆ Unequal Rabbet / 2-inch Face 4-inch Face Heads Available
- ◆ 5/8-inch Stop Height
- ◆ Exact Fit Mitered Corners
- ◆ 7-Gauge Hinge Reinforcement with Standard / Heavy Duty Adjustment
- ◆ 4-7/8" Universal Strike Preparation
- ◆ Floor Anchor Included
- ◆ 9/32-inch Silencer Preparation
- ◆ Wall Anchors for, Masonry, Wood Stud and Metal Stud Walls, Loose or Welded In.
- ◆ 4" - 13" Jamb Depth
- ◆ 20 Minute to 3 Hour Fire Label

**Accessories**

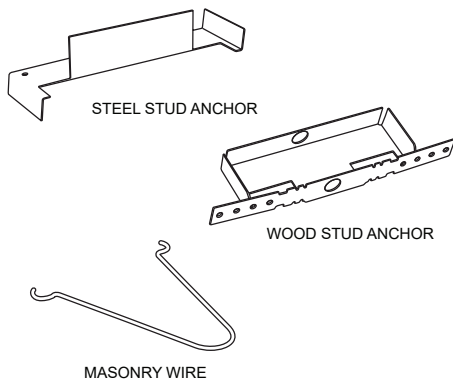

**Typical Hardware Preparations**

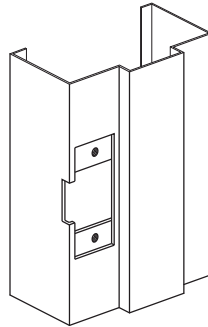

2-3/4" CYLINDRICAL STRIKE

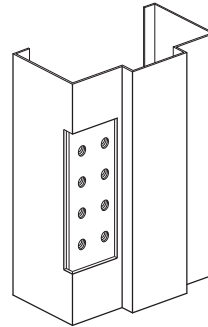

4-1/2" x 4-1/2"  
1-3/4" FRAME HINGE PREP

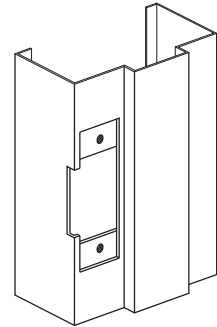

4-7/8" UNIVERSAL STRIKE

**Features**

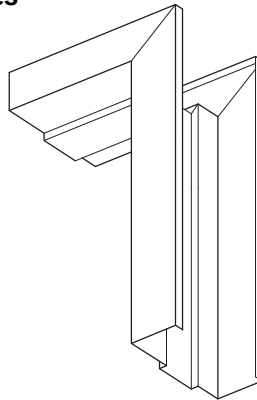

**WELDED CORNERS**  
Welded corners are tight fitting to provide a smooth seamless appearance

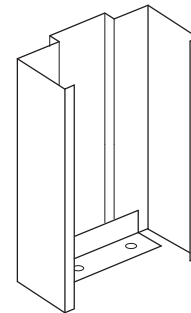

**FLOOR ANCHOR**  
18 Gauge floor anchors are standard in all masonry frames

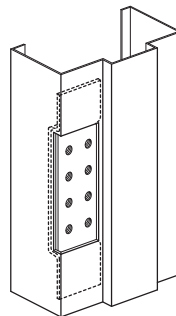

**HINGE REINFORCEMENT**  
7 Gauge standard / heavy duty hinge reinforcement

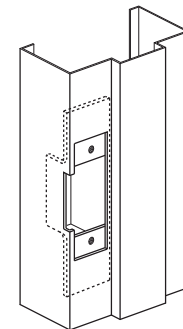

**STRIKE REINFORCEMENT**  
14 Gauge strike reinforcements and mortar boxes are designed for accurate and universal function





**Standard Features**

- ◆ 14-Gauge Cold Rolled or Galvanized Steel
- ◆ Unequal Rabbet / 2-inch Face 4-inch Face Heads Available
- ◆ 5/8-inch Stop Height
- ◆ Exact Fit Mitered Corners
- ◆ 7-Gauge Hinge Reinforcement with Standard / Heavy Duty Adjustment
- ◆ 4-7/8" Universal Strike Preparation
- ◆ Floor Anchor Included
- ◆ 9/32-inch Silencer Preparation
- ◆ Wall Anchors for, Masonry, Wood Stud and Metal Stud Walls, Loose or Welded In.
- ◆ 4" - 13" Jamb Depth
- ◆ 20 Minute to 3 Hour Fire Label

**Typical Hardware Preparations**

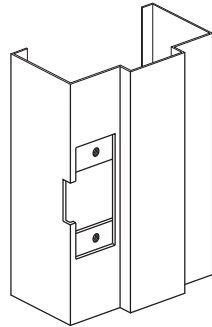

2-3/4" CYLINDRICAL STRIKE

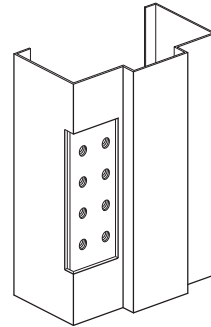

4-1/2" x 4-1/2"  
1-3/4" FRAME HINGE PREP

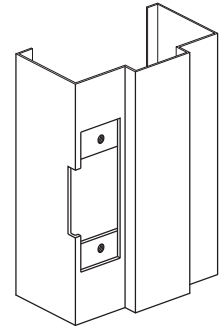

4-7/8" UNIVERSAL STRIKE

**Features**

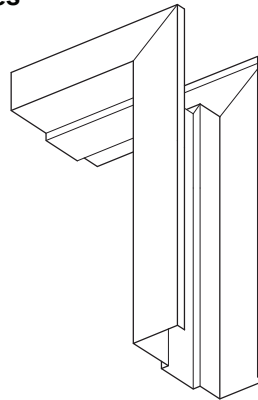

**WELDED CORNERS**  
Welded corners are tight fitting to provide a smooth seamless appearance

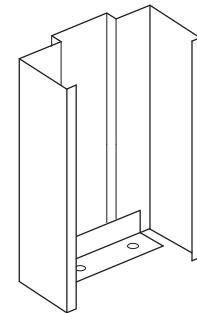

**FLOOR ANCHOR**  
18 Gauge floor anchors are standard in all masonry frames

**Accessories**

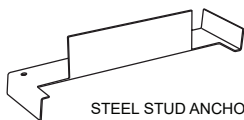

STEEL STUD ANCHOR

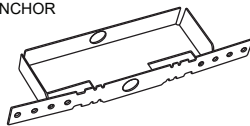

WOOD STUD ANCHOR

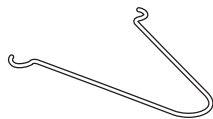

MASONRY WIRE

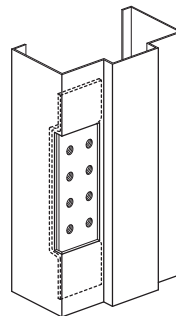

**HINGE REINFORCEMENT**  
7 Gauge standard / heavy duty hinge reinforcement

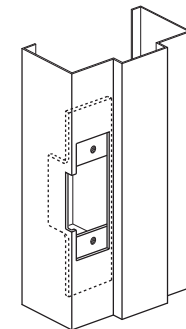

**STRIKE REINFORCEMENT**  
14 Gauge strike reinforcements and mortar boxes are designed for accurate and universal function







**Standard Features**

- ◆ 16-Gauge A-40 Galvanized Steel
- ◆ 3-Piece System Designed to Adjust to Multiple Depth Wall Conditions
- ◆ Slide Rails along the frame throat enables the frame to accommodate 4.625" to 7.75" Thick Walls
- ◆ Three 7-Gauge 4.5" x 4.5" Hinge Reinforcements for 6'8" and 7'0" Doors
- ◆ Four 7-Gauge 4.5" x 4.5" Hinge Reinforcements for 8' Doors
- ◆ Hinge Reinforcement Accepts Standard or Heavy Weight Template Hinges
- ◆ 12-Gauge ASA Strike Reinforcement
- ◆ Frame is Prepared for Silencer Operation
- ◆ 90 Minute WHI Mark as Standard

**Typical Hardware Preparations**

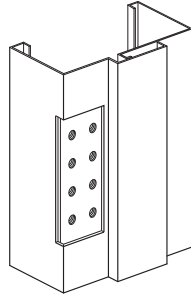

4-1/2" x 4-1/2"  
1-3/4" FRAME HINGE PREP

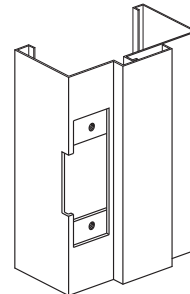

4-7/8" UNIVERSAL STRIKE

**Sections**

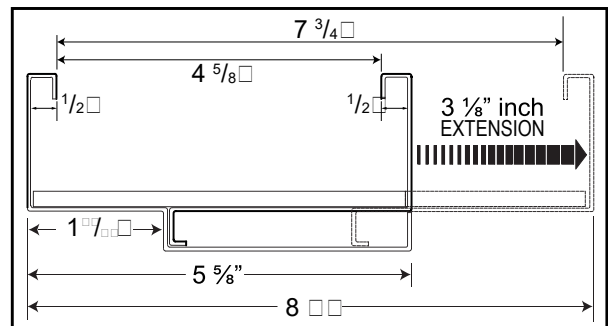
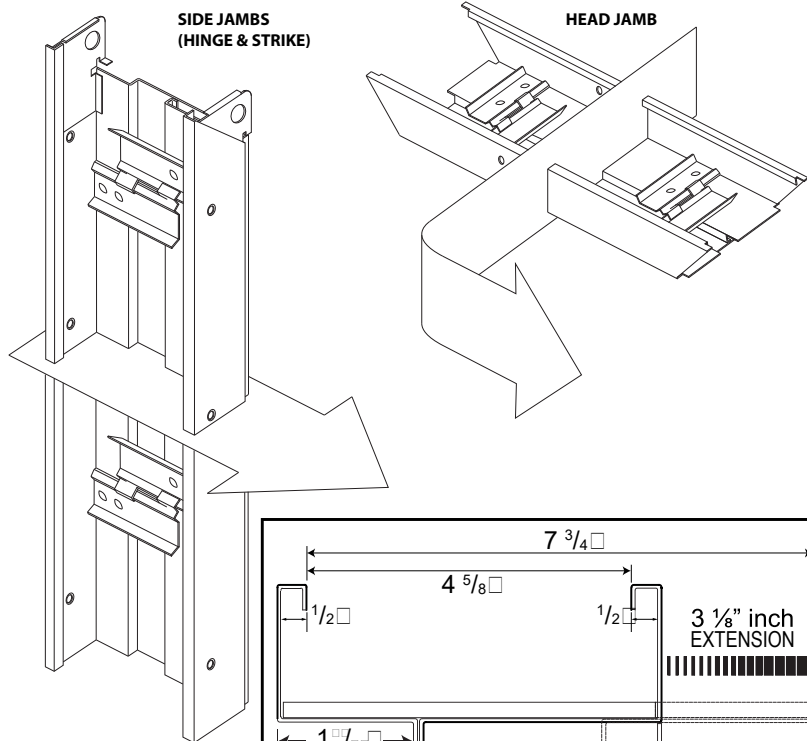



**Standard Features**

- ◆ 16-Gauge Cold Rolled Steel
- ◆ Unequal Rabbet / 2-inch Face
- ◆ 5/8-inch Stop Height
- ◆ Exact Fit Mitered Corners with Screw Reinforcement Between Head and Jamb Sides
- ◆ 7-Gauge Hinge Reinforcement with Standard / Heavy Duty Adjustment
- ◆ 4-7/8" Universal Strike Preparation
- ◆ Screw Adjusting Compression Anchors on Jamb Side
- ◆ 9/32-inch Silencer Preparation
- ◆ 5-5/8" - 9-3/4" Jamb Depth
- ◆ 1/2 inch Double Returns
- ◆ 20 to 90 Minute Fire Label
- ◆ Predrilled countersink holes

**Typical Hardware Preparations**

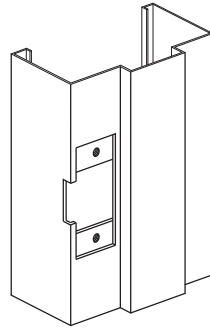

2-3/4" CYLINDRICAL STRIKE

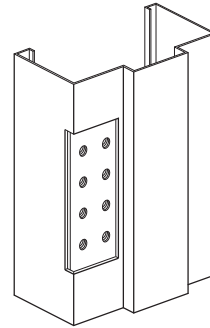

4-1/2" x 4-1/2"  
1-3/4" FRAME HINGE PREP

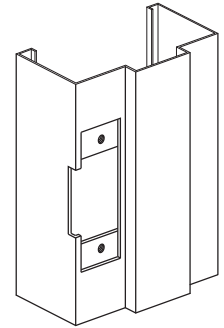

4-7/8" UNIVERSAL STRIKE

**Features**

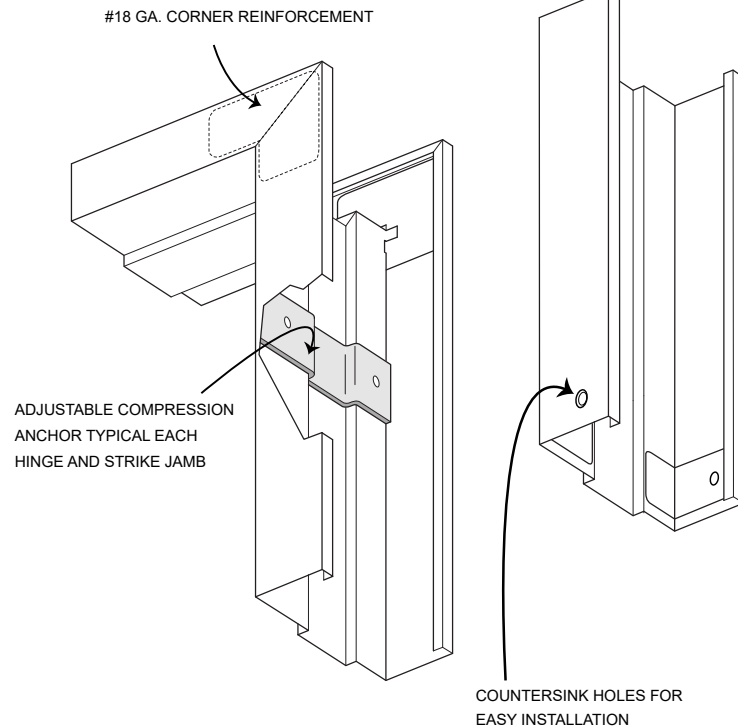

**Frame Profiles**

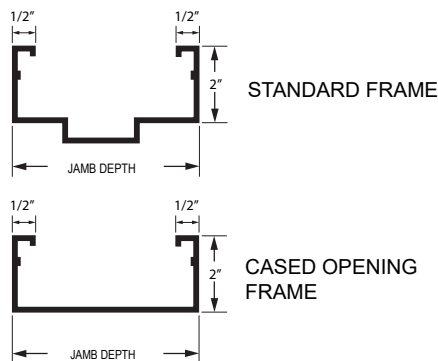



**7000 Series**

- ◆ 10-foot length blank fabrication material
- ◆ 16 and 14-Gauge A-40 Galvanized 2-inch face
- ◆ Unequal rabbet, cased open
- ◆ 4-inch face material
- ◆ Single return masonry
- ◆ 5.25 to 10.75-inch depths

**Mullions**

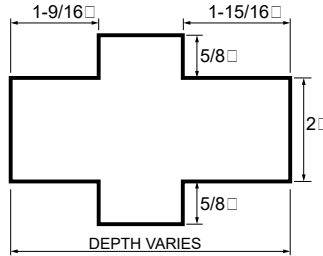

**Fab Sticks**

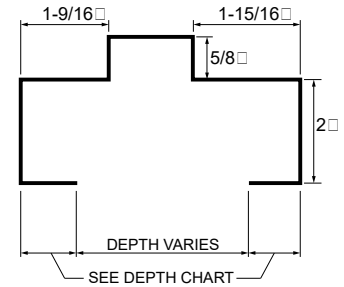

DEPTH CHART	
DEPTH	RETURNS
5.75	7/16
6.75	1/2
7.75	1/2
8.25	1/2
8.75	1/2

**8000 Series**

- ◆ 10-foot length blank fabrication material
- ◆ 16-Gauge cold rolled 2-inch face
- ◆ Unequal rabbet
- ◆ Double return drywall
- ◆ 5.625 to 9.75-inch depths

**7500 / 7800 Series**

- ◆ 10-foot length blank fabrication material
- ◆ Unequal rabbet
- ◆ 16-Gauge A-40 Galvanized and cold rolled material
- ◆ Hinge Mullion, Strike Mullion and Blank Mullion
- ◆ 10-foot hinge and strike jamb in 6x8 and 7x0 location

4.5 x 4.5 Hinge Reinforcements ◆ 7-Gauge Reinforcements ◆ 18-Gauge Floor Anchor ◆ Grey Prime

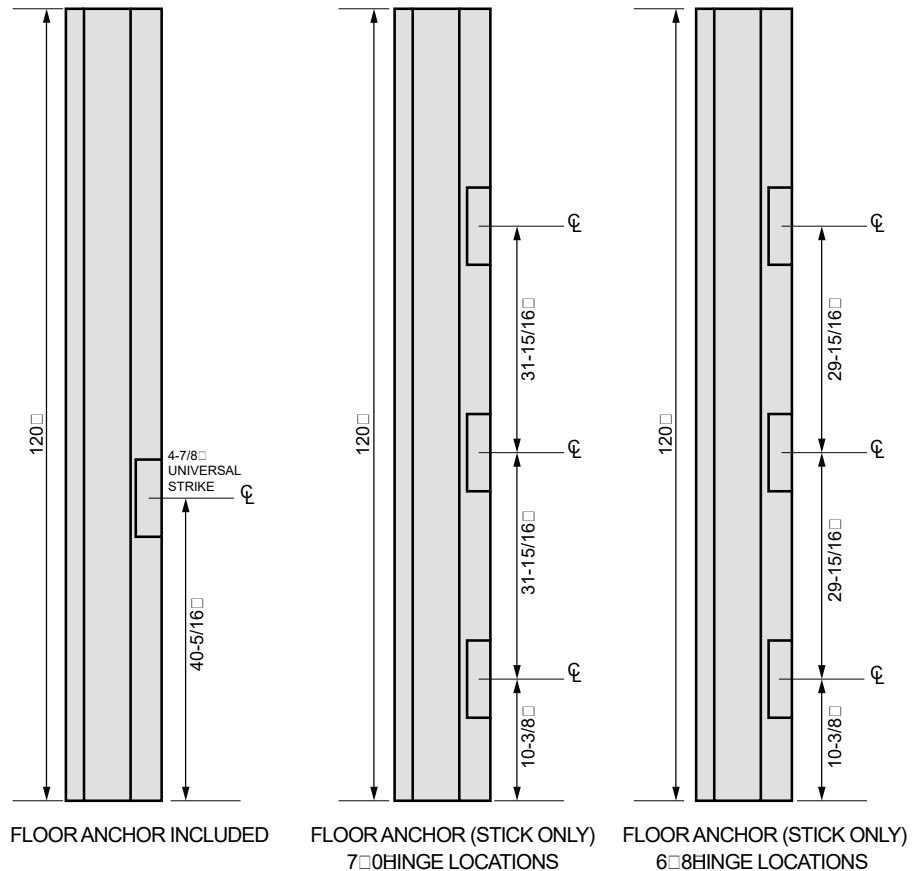



**STEEL DOOR & FRAME SYSTEMS, INC.**

**Vision Lite Low Profile  
20-180 Minute Fire Rated  
SVL Series**

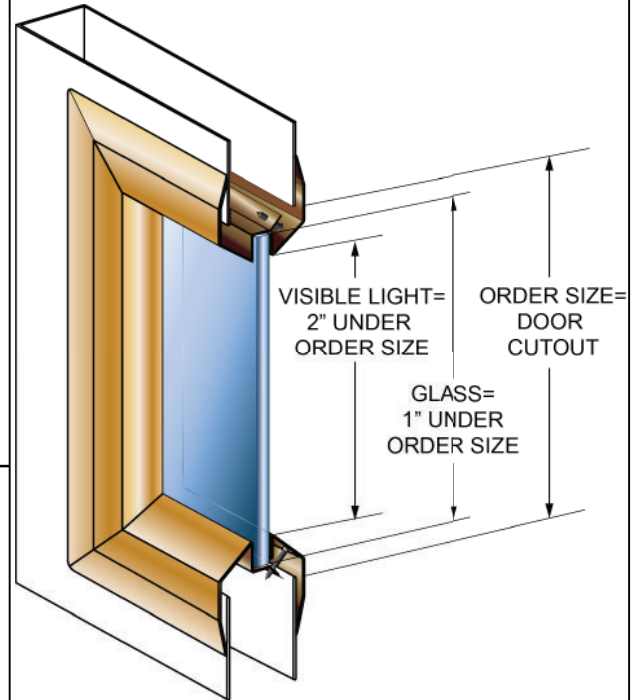
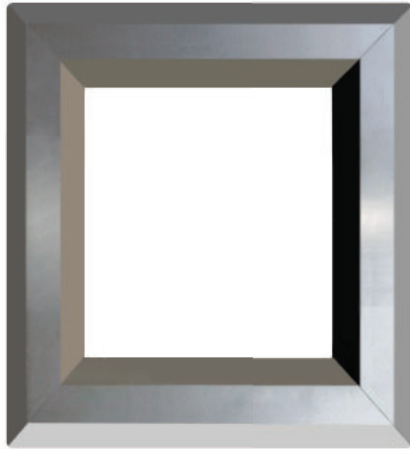

For use in Fire Rated door applications under positive and neutral pressure. Intertek testing certification in compliance to NFPA 252 (2008), UL 10C (2009), CAN/ULC 104 (2010), NFPA 252(2012) and CSI Code 0870 00 Hardware

**SPECIFICATIONS**

- Low Profile Beveled Vision Lite
- 20 Gauge Cold Rolled Steel
- Mitered welded corners with counter sunk mounting holes
- Single side attaching with matching mounting screws included
- For use with 3/16" to 1/4" glass thickness
- Designed for use with 1-3/4" doors only
- Baked on powder coat finish
- Color: Standard Bronze, Gray, AMS Beige, White, Sand, Silver, Black, SC Beige and Brass
- Fastener: #8 x 7/8" flathead phillips head SMS

**OPTIONS**

- Also available as a kit or bundle which comes with the Frame, Glass and Glazing Kit
- Available glass types are 1/4" Tempered (TEMP), 1/4" Superlite I-W Wired Glass (WS) and 3/16" Pyran® Platinum F Glass (PPF).

**NOTES**

- Order size is equal to opening size
- Visible vision opening is 2" under order size
- Glass size dimension is 1" under complete order size
- Follow all door manufacturer's instructions for use and installation of all products.
- Refer to Product No. Guide for list of fire rated sizes

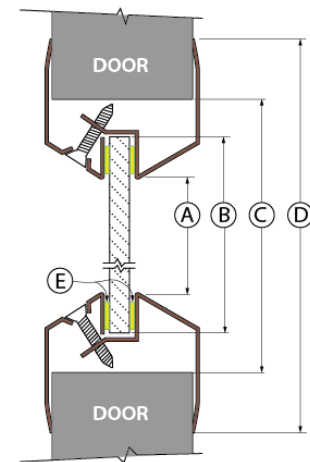

- (A) VISIBLE LIGHT = 2" UNDER ORDER SIZE
- (B) GLASS = 1" UNDER ORDER SIZE
- (C) ORDER SIZE = DOOR CUTOUT
- (D) 1-3/8" OVER ORDER SIZE
- (E) GLAZING TAPE



STEEL DOOR & FRAME SYSTEMS, INC.

Vision Lite Standard Profile  
20-180 Minute Fire Rated  
VL Series

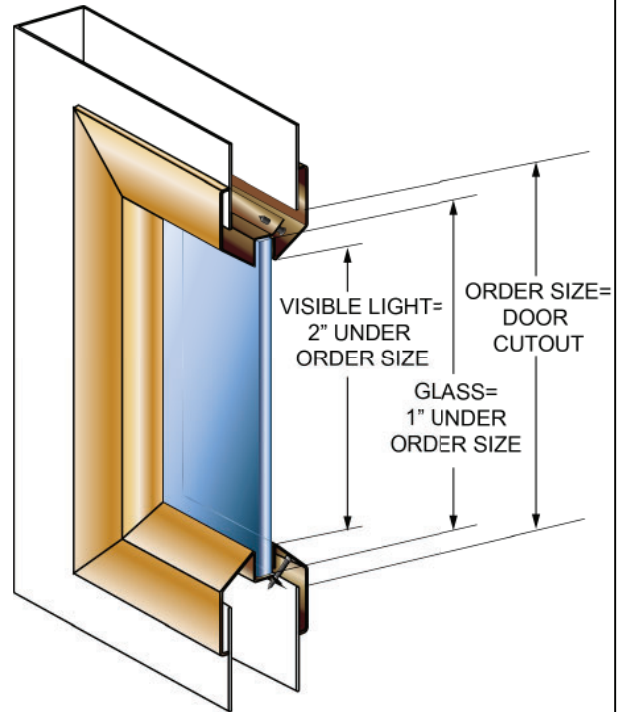

For use in Fire Rated door applications under positive and neutral pressure. Intertek testing certification in compliance to NFPA 252 (2008), UL 10C (2009), CAN/ULC 104 (2010), NFPA 252(2012) and CSI Code 0870 00 Hardware

**SPECIFICATIONS**

- Standard Profile Beveled Vision Lite
- 20 Gauge Cold Rolled Steel
- Mitered welded corners with counter sunk mounting holes
- Single side attaching with matching mounting screws included
- For use with 3/16" to 1/4" glass thickness
- Designed for use with 1-3/4" doors only
- Baked on powder coat finish
- Color: Standard Bronze, Gray, AMS Beige, White, Sand, Silver, Black, SC Beige and Brass
- Fastener: #8 x 7/8" flathead phillips head SMS

**OPTIONS**

- Also available as a kit or bundle which comes with the Frame, Glass and Glazing Kit
- Available glass types are 1/4" Tempered (TEMP), 1/4" Superlite I-W Wired Glass (WS) and 3/16" Pyran® Platinum F Glass (PPF).

**NOTES**

- Order size is equal to opening size
- Visible vision opening is 2" under order size
- Glass size dimension is 1" under complete order size
- Follow all door manufacturer's instructions for use and installation of all products.
- Refer to Product No. Guide for list of fire rated sizes

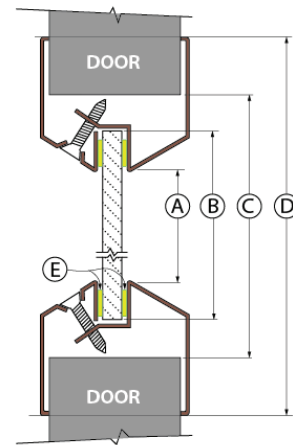

- (A) VISIBLE LIGHT = 2" UNDER ORDER SIZE
- (B) GLASS = 1" UNDER ORDER SIZE
- (C) ORDER SIZE = DOOR CUTOUT
- (D) 1-3/8" OVER ORDER SIZE
- (E) GLAZING TAPE



**STEEL DOOR & FRAME SYSTEMS, INC.**

**Vision Lite Standard Profile  
20-180 Minute Fire Rated  
10VL Series for 1" Glass**

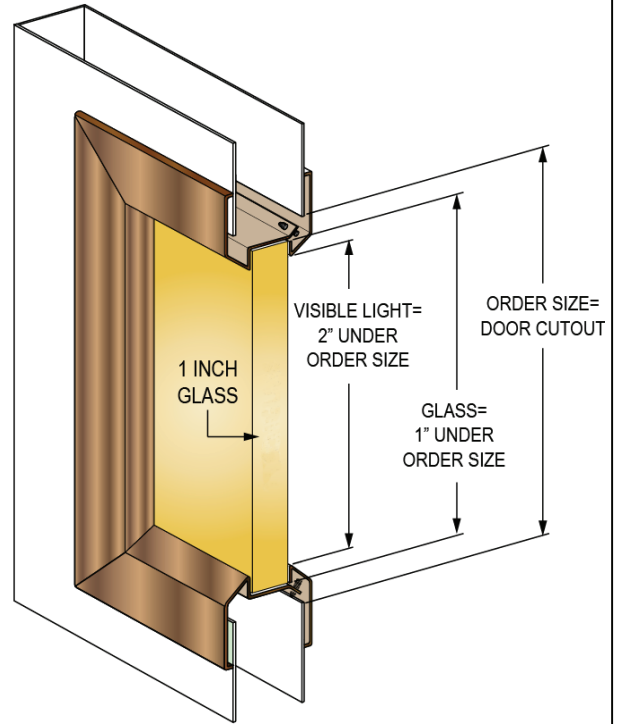

For use in Fire Rated door applications under positive and neutral pressure. Intertek testing certification in compliance to NFPA 252 (2008), UL 10C (2009), CAN/ULC 104 (2010), NFPA 252(2012) and CSI Code 0870 00 Hardware

**SPECIFICATIONS**

- Standard Profile Beveled Vision Lite
- 20 Gauge Cold Rolled Steel
- Mitered welded corners with counter sunk mounting holes
- Single side attaching with matching mounting screws included
- For use with 1" glass thickness
- Designed for use with 1-3/4" doors only
- Baked on powder coat finish
- Color: Standard Bronze, Gray, AMS Beige, White, Sand, Silver, Black, SC Beige and Brass
- Fastener: #8 x 7/8" flathead phillips head SMS

**NOTES**

- Order size is equal to opening size
- Visible vision opening is 2" under order size
- Glass size dimension is 1" under complete order size
- Follow all door manufacturer's instructions for use and installation of all products.

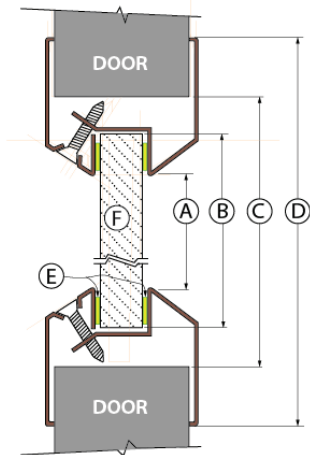

- (A) VISIBLE LIGHT = 2" UNDER ORDER SIZE
- (B) GLASS = 1" UNDER ORDER SIZE
- (C) ORDER SIZE = DOOR CUTOUT
- (D) 1-3/8" OVER ORDER SIZE
- (E) GLAZING TAPE
- (F) GLASS 1" THICK



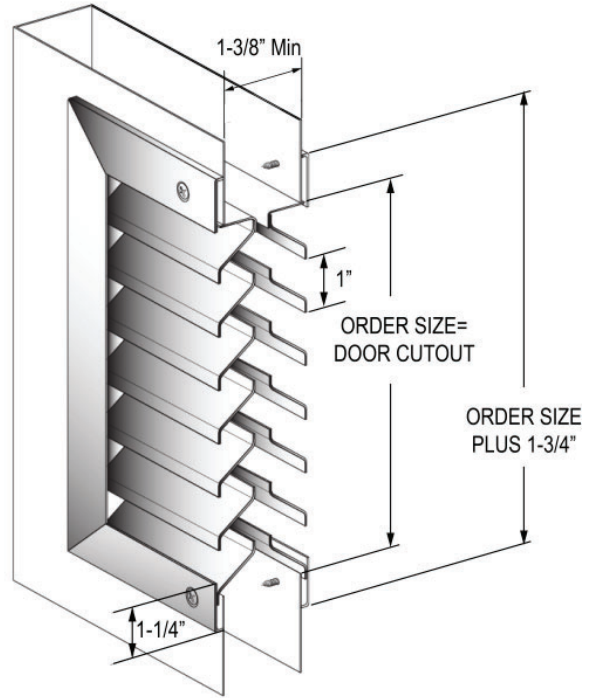
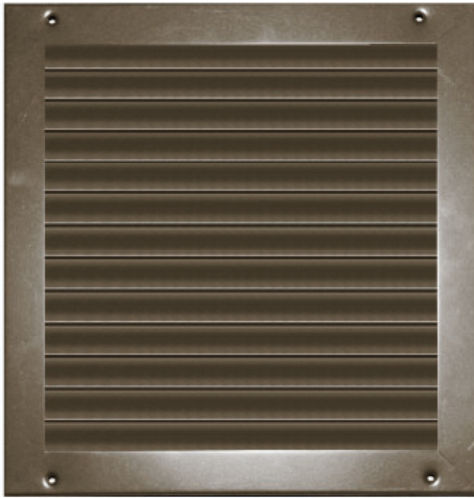

For use in Fire Rated door applications under positive and neutral pressure. Intertek testing certification in compliance to NFPA 252 (2000), UL 10C (2009), NFPA 252(2012) and CSI Code 089000 Louvers & Vents

**SPECIFICATIONS**

- 18 Gauge Cold Rolled Steel Frame & Blades
- Mitered welded corner frame construction
- Divided row "Y" blades spaced at 1" increments with blocked vision design
- Counter sunk mounting holes with screws for each side of the door
- Minimum door size thickness: 1-3/8"
- Baked on powder coat finish
- Color: Standard Bronze
- Fastener: Phillips head screws #8 x 3/4"

**NOTES**

- Order size is equal to opening size
- Follow all door manufacturer's instructions for use and installation of all products.

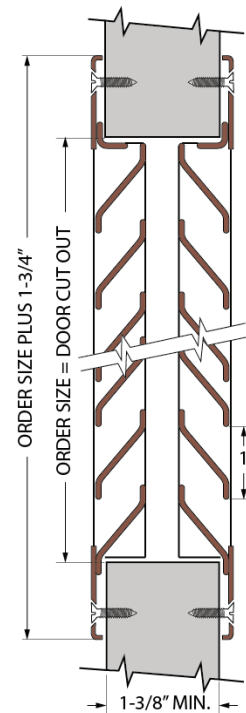



STEEL DOOR & FRAME SYSTEMS, INC.

Inverted "Y" Blade Louvers  
90 Minute Fire Rated  
VLV Series

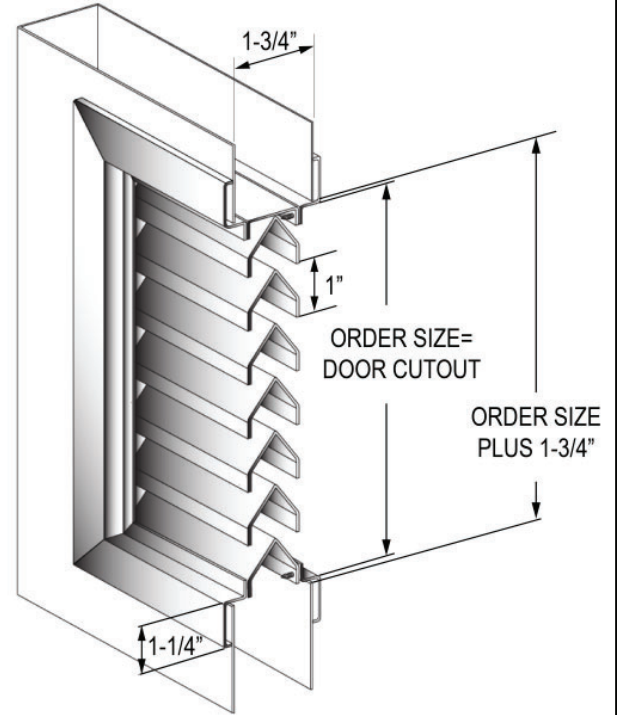

For use in Fire Rated door applications under positive and neutral pressure. Intertek testing certification in compliance to NFPA 252 (2000), UL 10C (2009), NFPA 252(2012) and CSI Code 089000 Louvers & Vents

**SPECIFICATIONS**

- 18 Gauge Cold Rolled Steel Frame & Blades
- Mitered welded corner frame construction
- Reverse "Y" blades are frame supported at 1" increments, with blocked vision design
- Single side mounting for non corridor exposure with fastening screws included
- Design for use with 1-3/4" doors only
- Baked on powder coat finish
- Color: Standard Bronze
- Fastener: Phillips head screws #8 x 3/4"

**NOTES**

- Order size is equal to opening size
- Follow all door manufacturer's instructions for use and installation of all products.

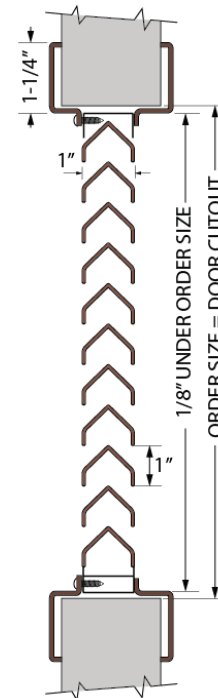





STEEL DOOR & FRAME SYSTEMS, INC.

## Adjustable Fusible Link Louvers 90 Minute Fire Rated FLLV Series



Adjustable Fusible Link Louvers are recommended for use in rooms where ventilation is needed and at the same time isolating the room whenever fire is present. When louver is exposed to heat at 165°F, the fusible link trips and the spring loaded louver blades shut to form an air tight fire and smoke seal.

UL (WHI Listing Mark) is stamped on the frame of the louvers with a 60-90 Minutes Fire Rating. Installation is easy. No need to drill holes for fasteners. All screws are mounted on the room side leaving the corridor side free of fasteners for security purposes.

Fuses are replaceable.

### Standard Features:

Material: 16 Gauge CRS Frame & Louver Blades

Door: for 1-3/4" Doors only

Fasteners: 3 x 3/4" LG & 1 x 1/2" LG

Finish: Standard Bronze

Free Flow Area: 45% free

### Construction:

- Welded & mitered corners
- Adjustable blades of 16-gauge CRS
- Cadmium plated steel rivets
- Cadmium plated steel tension spring
- 1-9/16" deep louver assembly

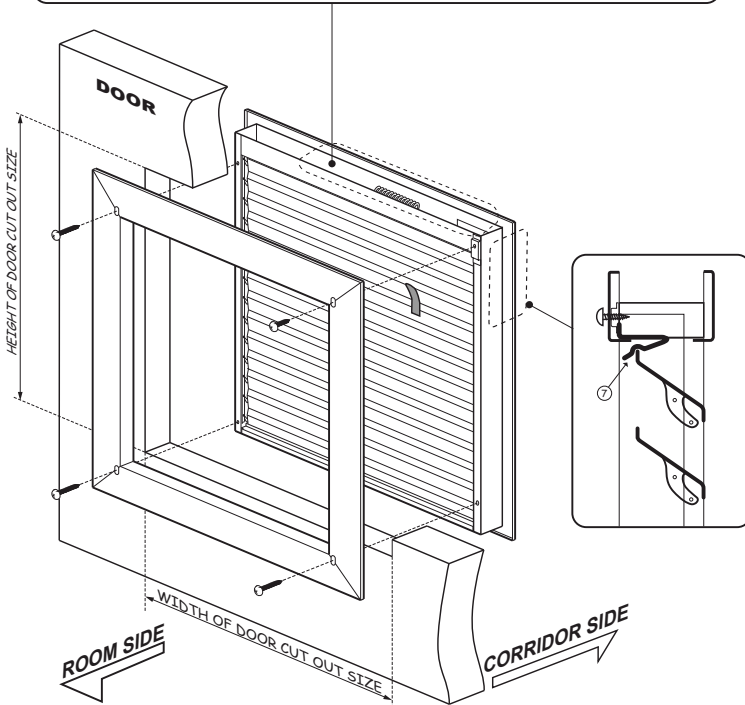
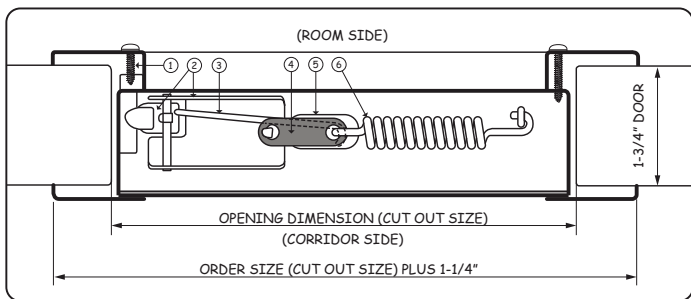

- ① Mounting Screws - #8 phillips head  
(3 x 3/4" LG & 1 x 1/2" LG)
- ② Rocker Arm, Closing Bar and housing
- ③ "S" Hook - .080" Cadmium plated steel
- ④ Fusible link - Design temperature 165° F max
- ⑤ Heat opening - 1/2" x 1"
- ⑥ Tension spring - 3" LG x 1/2" dia x .063" thick Cadmium plated steel.
- ⑦ Flat Spring Clip

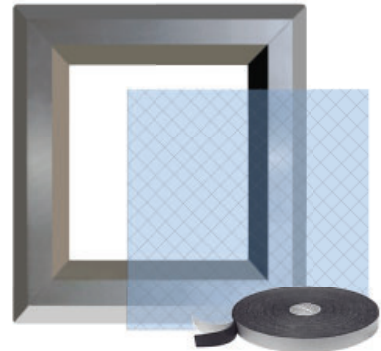
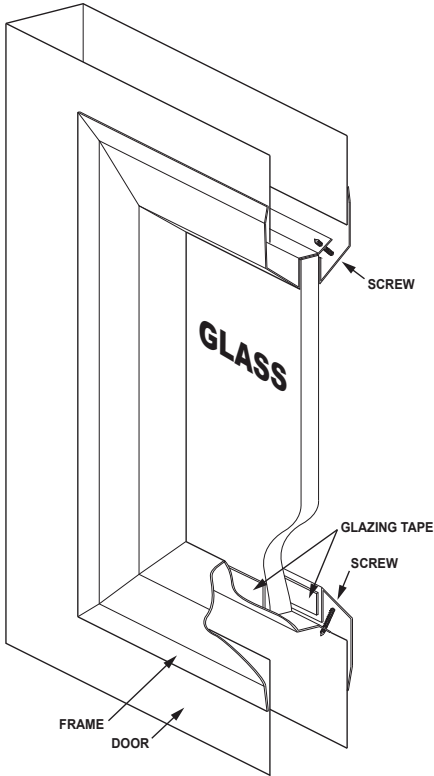

LOW PROFILE SVL VISION LITE KITS

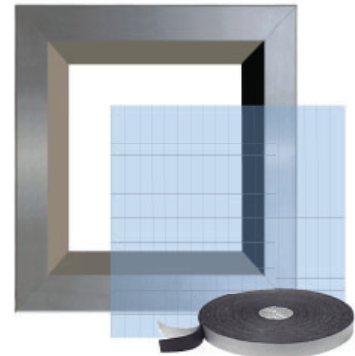

STANDARD PROFILE VL VISION LITE KITS

For use in Fire Rated door applications under positive and neutral pressure. Intertek testing certification in compliance to NFPA 252 (2000), UL 10C (2009), CAN/ULS104 (2010), NFPA (201) and CSI Code 0870 00

**FRAME SPECIFICATIONS**

- Standard and Low Profile Vision Lite Kits
- 20 Gauge Cold Rolled Steel
- Mitered welded corners with counter sunk mounting holes
- Single side attaching with matching mounting screws included
- For use with 3/16" to 1/4" glass thickness
- Designed for use with 1-3/4" doors only
- Baked on powder coat finish
- Color: Standard Bronze, Gray, AMS Beige, White, Sand, Silver, Black, SC Beige and Brass
- Fastener: #8 x 7/8" flathead phillips head SMS

**NOTES**

- Order size is equal to opening size
- Visible vision opening is 2" under order size
- Glass size dimension is 1" under complete order size
- Follow all door manufacturer's instructions for use and installation of all products.

**GLAZING TAPE**

- Standard 1/16" x 3/8" applied to both sides of glass

**GLASS OPTIONS**

**TEMP** (Tempered Glass): Heat-strengthened glass and cannot be cut after manufacturing. Fire Rating: None. Clear wire free glass recommended for non fire rated applications. Use of glazing compound or glazing tape on both sides of glass is recommended to minimize breakage.

Size: Minimum 2" x 2", max sheet size: 88" x 118".

**WS** (Superlite I-W Wired Glass): 20 ga CRS (Cold Rolled Steel) beveled vision lite, 1/4" wired glass with film. Glass is UL labeled standard.

Fire Rating: 20 minutes to 90 minutes. Install in fire listed and labeled vision frames. Use of glazing compound or glazing tape on both sides of glass is recommended to minimize breakage.

Size: Minimum 4" x 4", max rated size: 36" x 84".

**PPF** (PYRAN® Platinum F Glass): Glass is UL labeled standard.

Fire Rating: 20 minute to 3 hours. Install in fire listed and labeled vision frames. Use of glazing compound or glazing tape on both sides of glass is recommended to minimize breakage.

Size: Minimum 4" x 6", max sheet size: 43" x 77".

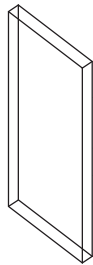

**Tempered Glass**

- ← Heat-treated clear safety glass that breaks into small particles
- ← Light Transmission: 86% approx
- ← Thickness: 1/4" (6 mm)
- ← Non-Fire Rated

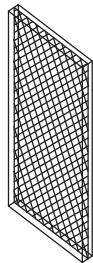

**SuperLite I-W Wired Glass**

- ← Embedded 3/4" x 3/4" wire mesh
- ← Light Transmission: 86% approx
- ← Thickness: 1/4" (6 mm)
- ← Annealed single glazing with safety film applied to one side
- ← 20-90 Minute Fire Rating

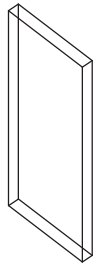

**PYRAN® Platinum F Glass**

- ← Glass Ceramic
- ← Light Transmission: 80% approx
- ← Surface applied Heavy Duty Safety film
- ← Thickness: 3/16" (5 mm)
- ← 20-180 Minute Fire Rating

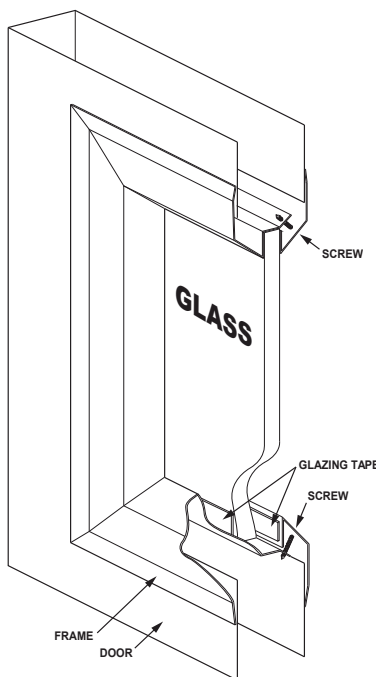
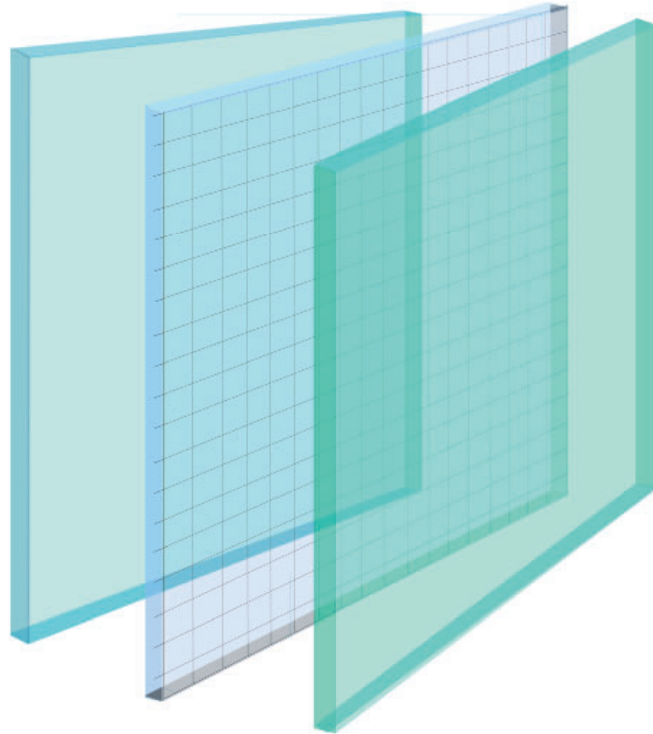

**GLASS OPTIONS**

**TEMP** (Tempered Glass): Heat-strengthened glass and cannot be cut after manufacturing. Fire Rating: None. Clear wire free glass recommended for non fire rated applications. Use of glazing compound or glazing tape on both sides of glass is recommended to minimize breakage.  
Size: Minimum 2" x 2", max sheet size: 88" x 118".

**WS** (Superlite I-W Wired Glass): 20 ga CRS (Cold Rolled Steel) beveled vision lite, 1/4" wired glass with film. Glass is UL labeled standard. Fire Rating: 20 minutes to 90 minutes. Install in fire listed and labeled vision frames. Use of glazing compound or glazing tape on both sides of glass is recommended to minimize breakage.  
Size: Minimum 4" x 4", max rated size: 36" x 84".

**PPF** (PYRAN® Platinum F Glass): Glass is UL labeled standard. Fire Rating: 20 minute to 3 hours. Install in fire listed and labeled vision frames. Use of glazing compound or glazing tape on both sides of glass is recommended to minimize breakage.  
Size: Minimum 4" x 6", max sheet size: 43" x 77".